

Model 10882A

IRIG-B Distribution Tap

Operating Instructions



Document No. PD0045500A

Arbiter Systems, Inc.
1324 Vendels Circle, Suite 121
Paso Robles, CA 93446 U.S.A.
(805) 237-3831, (800) 321-3831
<http://www.arbiter.com>
[mailto: techsupport@arbiter.com](mailto:techsupport@arbiter.com)

1 Introduction

These instructions cover the specifications and operation of the Model 10882A, IRIG-B Distribution Tap. When connected to a system bus, the Model 10882A is used to provide a decoupled, isolated output signal to your system loads.

The Model 10882A is one in a family of passive devices designed to distribute modulated IRIG-B signals to devices connected to a bus. Specifically the 10882A was designed to operate when connected to an Option 18 mounted in a Model 1088A/B GPS synchronized clock. Other devices in the IRIG-B distribution product family include the Model 10883A Distribution Splitter, the Model 10884A Terminator, and the Model 10885A Redundant Ring Adapter. All of these devices may be combined to form a simple or complex bus system as seen in Figure 2, and are optionally available with DIN rail mounting clips.

2 Specifications

- Output Level, Tap Output: 6.4 to 11 Vpp, open circuit; 3.2 to 5.5 Vpp, into 600-ohm load.
- Isolation: 3750 Vrms, from distribution bus to load.
- Source Impedance: 600 ohms, approximate.
- Protection: surge suppression & EMI filtering.
- Size without DIN rail: 52 × 39 × 45mm (2.0 × 1.5 × 1.8in.), overall height including pluggable terminal connectors.
- Size with DIN rail & pluggable terminals: 52 × 39 × 58mm (2.0 × 1.5 × 2.3in.).
- Weight: with pluggable terminal connectors and without DIN rail mounts: 94g (3.30oz.).
- Connectors: Phoenix pluggable terminals (5-mm centers) with removable screw-clamp terminal block, accepting 0.2 – 4 mm² (AWG 24 - 10) solid or stranded conductors.
- Temperature, operating: -10°C to +50°C, non-operating: -40°C to +75°C
- Humidity: non-condensing

3 Operation

Strip twisted pair wiring approximately 1/4 inch and insert into input and output pluggable terminal blocks according to wiring diagram shown in Figure 1, and tighten screws to secure wire. Insert terminal blocks into plug on 10882A. *Do not tin stripped wire with solder before inserting into pluggable terminal blocks.* For additional details, see Application Note 101 available on the Arbiter Systems website, www.arbiter.com.

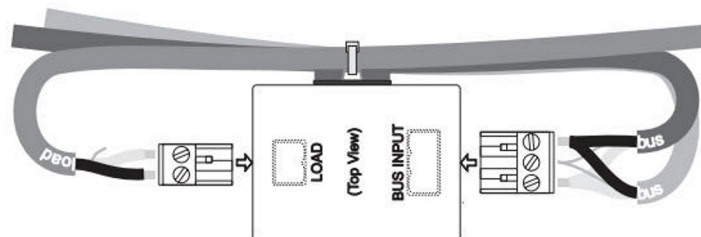
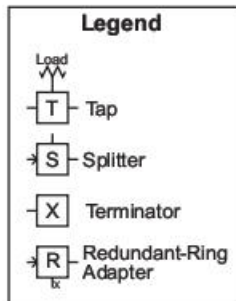
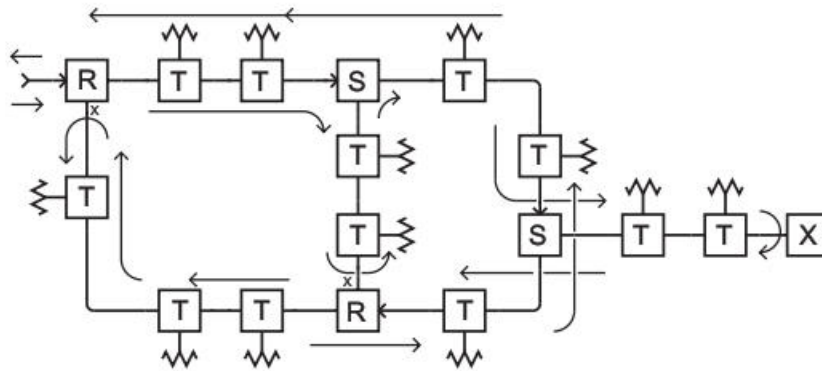
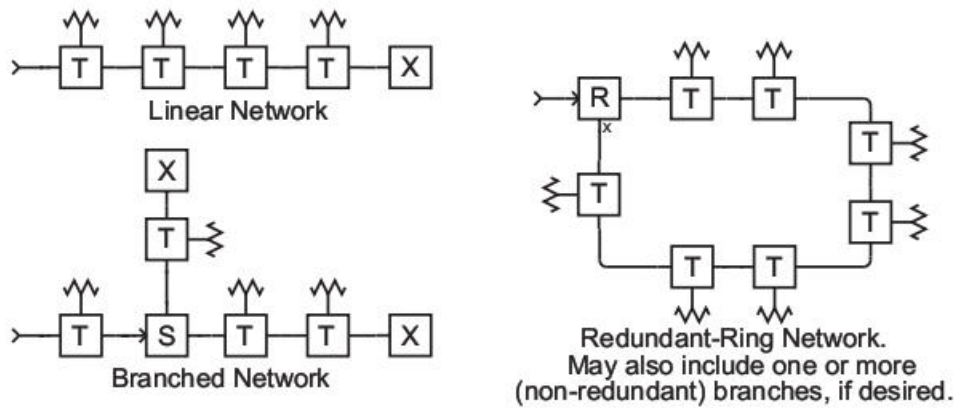

Figure 1: 10882A Connection Wiring Diagram



Complex network, showing multiple loops and branches. Arrows show direction of dc loop monitor current flow.

Bus Cable: Belden 8760 or equivalent; 18 AWG pair with foil-polyester shield and 20 AWG drain wire.

Figure 2: Typical Network Connections