



IRIG SERIAL TIME CODE FORMATS

**ABERDEEN TEST CENTER
DUGWAY PROVING GROUND
REAGAN TEST SITE
WHITE SANDS MISSILE RANGE
YUMA PROVING GROUND**

**NAVAL AIR WARFARE CENTER AIRCRAFT DIVISION
NAVAL AIR WARFARE CENTER WEAPONS DIVISION
NAVAL UNDERSEA WARFARE CENTER DIVISION, KEYPORT
NAVAL UNDERSEA WARFARE CENTER DIVISION, NEWPORT
PACIFIC MISSILE RANGE FACILITY**

**30TH SPACE WING
45TH SPACE WING
96TH TEST WING
412TH TEST WING
ARNOLD ENGINEERING DEVELOPMENT COMPLEX**

NATIONAL AERONAUTICS AND SPACE ADMINISTRATION

**DISTRIBUTION A: APPROVED FOR PUBLIC RELEASE
DISTRIBUTION IS UNLIMITED**

This page intentionally left blank.

IRIG SERIAL TIME CODE FORMATS

August 2016

Prepared by

**TIMING COMMITTEE
TELECOMMUNICATIONS AND TIMING GROUP**

Published by

**Secretariat
Range Commanders Council
U.S. Army White Sands Missile Range,
New Mexico 88002-5110**

This page intentionally left blank.

Table of Contents

Preface.....	ix
Acronyms.....	xi
Chapter 1. Introduction.....	1-1
Chapter 2. General Description of this Standard	2-1
Chapter 3. General Description of Time Code Formats	3-1
3.1 Pulse Rise Time	3-1
3.2 Jitter.....	3-1
3.3 Bit Rates and Index Count	3-1
3.4 Time Frame, Time Frame Reference, and Time Frame Rates.....	3-1
3.5 Position Identifiers	3-2
3.6 Time Code Words.....	3-2
3.7 BCD Time-of-Year Code Word.....	3-2
3.8 Control Functions.....	3-3
3.9 Index Markers	3-4
3.10 Amplitude-Modulated Carrier	3-4
Chapter 4. Detailed Description of Formats.....	4-1
4.1 Serial Time Code Formats (A, B, D, E, and G).....	4-1
4.2 Examples of Typical Modulated Carrier Signal Formats for IRIG A, B, E, and G.....	4-2
4.3 Manchester II Coding	4-5
4.4 Manchester II Decoding.....	4-7
Chapter 5. Detailed Description of Time Codes	5-1
5.1 Introduction.....	5-1
5.2 Format A	5-1
5.3 Format B	5-5
5.4 Format D.....	5-9
5.5 Format E.....	5-12
5.6 Format G	5-16
5.7 Format H.....	5-20
Appendix A. Leap Year/Leap Second Conventions	A-1
A.1 Leap Year Convention	A-1
A.2 Leap Second Convention	A-1
Appendix B. BCD Count/Binary Count.....	B-1
Appendix C. Hardware Design Considerations.....	C-1
Appendix D. Glossary	D-1

D.1 Definitions of Terms And Usage D-1

Appendix E. Citations..... E-1

List of Figures

Figure 3-1. Typical Modulated Carrier Signal 3-5

Figure 4-1. Serial Time Code Formats 4-1

Figure 4-2. IRIG B Coding Comparisons: Level Shift, 1 khz am, and Modified Manchester 4-6

Figure 4-3. Modified Manchester Coding 4-6

Figure 4-4. A Manchester II Encoded Sequence 4-7

Figure 5-1. Format A: BCD Time-of-Year in Days, Hours, Minutes, Seconds, Fractions of Seconds, Year, Straight Binary Seconds Time-of-Day, and Control Bits 5-2

Figure 5-2. Format B: BCD Time-of-Year in Days, Hours, Minutes, Seconds, Year, Straight Binary Seconds Time-of-Day, and Control Bits. 5-6

Figure 5-3. Format D: BCD Time-of-Year in Days and Hours and Control Bits 5-10

Figure 5-4. Format E: BCD Time-of-Year in Days, Hours, Minutes, Seconds, and Year and Control Bits 5-13

Figure 5-5. Format G: BCD Time-of-Year in Days, Hours, Minutes, Seconds, and Year and Fractions-of-Seconds, and Control Bits 5-17

Figure 5-6. Format H: BCD Time-of-Year in Days, Hours, Minutes, and Control Bits 5-21

List of Tables

Table 3-1. Bit Rates And Index Count Intervals Of The Time Code Formats..... 3-1

Table 3-2. Time Frame Rates And Time Frame Intervals Of The Formats 3-2

Table 3-3. Position Identifiers And Index Count Locations 3-2

Table 3-4. Number of Available Control Bits in Each Time Code Format 3-3

Table 3-5. Typical Modulated Carrier Signal Formats for A, B, E, D, G, and H 3-6

Table 4-1. Permissible Code Formats (A, B, D, E, G, H) 4-2

Table 4-2. Typical Modulated Carrier Signal Formats (IRIG A)..... 4-2

Table 4-3. Typical Modulated Carrier Signal Formats (IRIG B)..... 4-3

Table 4-4. Typical Modulated Carrier Signal Formats (IRIG E) 4-4

Table 4-5. Typical Modulated Carrier Signal Formats (IRIG G)..... 4-4

Table 4-6. Truth Table Is A Modulo-2 Adder 4-7

Table 5-1. Format A, Signal A000 5-3

Table 5-2. IRIG-A Control Bit Assignment for Year Information 5-4

Table 5-3. Parameters for Format A..... 5-5

Table 5-4. Format B, Signal B000 5-7

Table 5-5. IRIG-B Control Bit Assignment for Year Information..... 5-8

Table 5-6. Parameters for Format B 5-9

Table 5-7. Format D, Signal D001 5-11

Table 5-8. Parameters for Format D..... 5-12

Table 5-9. Format E, Signal E001 5-14

Table 5-10. IRIG-E Control Bit Assignment For Year Information..... 5-15

Table 5-11.	Parameters for Format E	5-16
Table 5-12.	Format G, Signal G001	5-18
Table 5-13.	IRIG-G Control Bit Assignment for Year Information	5-19
Table 5-14.	Parameters For Format G.....	5-20
Table 5-15.	Format H, Signal H001	5-22
Table 5-16.	Parameters for Format H.....	5-23
Table B-1.	BCD Count (8n 4n 2n 1n).....	B-1
Table B-2.	Binary Count (2n)	B-1
Table C-1.	Time Code Generator Hardware Minimum Design Considerations.....	C-1

This page intentionally left blank.

Preface

IRIG Standard 200 was last updated in September 2004 and added year information for the IRIG timecodes. This 2016 edition of the standard corrects minor technical errors throughout the document. The task of revising this standard was assigned to the Telecommunications and Timing Group of the Range Commanders Council.

All U.S. Government ranges and facilities should adhere to this standard where serial time codes are generated for correlation of data with time.

Please direct any questions regarding this document to the RCC Secretariat as shown below.

Secretariat, Range Commanders Council
ATTN: CSTE-WS-RCC
1510 Headquarters Avenue
White Sands Missile Range, New Mexico 88002-5110
Phone: DSN 258-1107 Com (575) 678-1107
Fax: DSN 258-7519 Com (575) 678-7519
Email: usarmy.wsmr.atec.list.rcc@mail.mil

This page intentionally left blank.

Acronyms

μ s	microsecond (10^{-6} s)
BCD	binary coded decimal
BIH	Bureau International de l'Heure
CF	control function
d	day
dc	direct current
DoD	Department of Defense
fph	frames per hour
fpm	frames per minute
fps	frames per second
GPS	Global Positioning System
h	hour
Hz	hertz
k	1000
kHz	kilohertz (1000 Hz)
LSB	least significant bit
m	minute
mo	month
ms	millisecond (10^{-3} s)
MSB	most significant bit
NASA	National Aeronautics and Space Administration
NRZ-L	non-return-to-zero level
ns	nanosecond (10^{-9} s)
pph	pulses per hour
ppm	pulses per minute
pps	pulses per second
s	second
SBS	straight binary second(s)
TAI	International Atomic Time
TOD	time-of-day
TOY	time-of-year
USNO	United States Naval Observatory
UTC	Coordinated Universal Time
y	year

This page intentionally left blank.

CHAPTER 1

Introduction

Modern-day electronic systems such as communication systems, data handling systems, and missile and spacecraft tracking systems require time-of-day (TOD) and time-of-year (TOY) information for correlation of data with time. Parallel and serial formatted time codes are used to efficiently interface the timing system output with the user system. Parallel time codes are defined in IRIG Standard 205-87.¹ Standardization of time codes is necessary to ensure system compatibility among the various ranges, ground tracking networks, spacecraft and missile projects, data reduction facilities, and international cooperative projects.

This standard defines the characteristics of six serial time codes presently used by the U.S. Government and private industry. Year information has been added to IRIG codes A, B, E, and G. It should be noted that this standard reflects the present state of the art in serial time code formatting and is not intended to constrain proposals for new serial time codes with greater resolution.

All Department of Defense (DoD) test ranges, facilities, and other government agencies such as the National Aeronautics and Space Administration (NASA) maintain Coordinated Universal Time (UTC) referenced to the United States Naval Observatory (USNO) Master Clock. The designation for time in the United States is UTC (USNO).

¹ Range Commanders Council. *IRIG Standard Parallel Binary and Parallel Binary Coded Decimal Time Code Formats*. RCC 205-87. August 1987. May be superseded by update. Retrieved on 29 July 2015. Available to RCC members with Private Page access at https://wsgmext.wsmr.army.mil/site/rccpri/Publications/205-87_IRIG_Standard_Parallel_Binary_and_Parallel_Binary_Coded_Decimal_Time_Code_Formats/.

This page intentionally left blank.

CHAPTER 2

General Description of this Standard

This standard consists of a family of rate-scaled serial time codes with formats containing up to four coded expressions or words. All time codes contain control functions (CFs) that are reserved for encoding various controls, identification, and other special-purpose functions. Time codes A, B, D, E, G, and H are described below.

- Time code A has a time frame of 0.1 seconds with an index count of 1 millisecond and contains TOY in days, hours, minutes, seconds, tenths of seconds, and year information in a binary coded decimal (BCD) format and seconds-of-day in straight binary seconds (SBS).
- Time code B has a time frame of 1 second with an index count of 10 milliseconds and contains TOY in days, hours, minutes, seconds, and year information in a BCD format and seconds-of-day in SBS.
- Time code D has a time frame of 1 hour with an index count of 1 minute and contains TOY information in days and hours in a BCD format.
- Time code E has a time frame of 10 seconds with an index count of 100 milliseconds and contains TOY in days, hours, minutes, seconds, and year information in a BCD format.
- Time code G has a time frame of 0.01 seconds with an index count of 0.1 milliseconds and contains TOY information in days, hours, minutes, seconds, tenths, and hundredths of seconds and year information in a BCD format.
- Time code H has a time frame of 1 minute with an index count of 1 second and contains TOY information in days, hours, and minutes in a BCD format.

This page intentionally left blank.

CHAPTER 3

General Description of Time Code Formats

The time code formats are described in the paragraphs below. Additional reference information is provided at the end of this document on the related topics of leap year and leap second conventions ([Appendix A](#)), BCD count data and binary count data ([Appendix B](#)), and time code generator hardware design considerations ([Appendix C](#)).

3.1 Pulse Rise Time

The specified pulse (direct current [dc] level shift bit) rise time shall be obtained between the 10 and 90% amplitude points (see [Appendix C](#)).

3.2 Jitter

The modulated code is defined as $\leq 1\%$ at the carrier frequency. The dc level shift code is defined as the pulse-to-pulse variation at the 50% amplitude points on the leading edges of successive pulses or bits (see [Appendix C](#)).

3.3 Bit Rates and Index Count

Each pulse in a time code word/subword is called a bit. The on-time reference point for all bits is the leading edge of the bit. The repetition rate at which the bits occur is called the bit rate. Each bit has an associated numerical index count identification. The time interval between the leading edge of two consecutive bits is the index count interval. The index count begins at the frame reference point (the leading edge of the reference bit [P_r]) with index count 0 and increases one count each index count until the time frame is complete.

The bit rates and index count intervals of the time code formats are shown in [Table 3-1](#).

Table 3-1. Bit Rates And Index Count Intervals Of The Time Code Formats		
Format	Bit Rate¹	Index Count Interval
A	1 kpps	1 millisecond
B	100 pps	10 milliseconds
D	1 ppm	1 minute
E	10 pps	0.1 second
G	10 kpps	0.1 millisecond
H	1 pps	1 second

¹ See the [Acronyms](#) list for bit rate definitions.

3.4 Time Frame, Time Frame Reference, and Time Frame Rates

A time code frame begins with a frame reference marker P_0 (position identifier) followed by a reference bit P_r with each having duration equal to 0.8 of the index count interval of the respective code. The on-time reference point of a time frame is the leading edge of the reference bit P_r . The repetition rate at which the time frames occur is called the time frame rate. The time frame rates and time frame intervals of the formats are shown in [Table 3-2](#).

Format	Time Frame Rate	Time Frame Interval
A	10 fps	0.1 second
B	1 fps	1 second
D	1 fph	1 hour
E	6 fpm	10 seconds
G	100 fps	10 ms
H	1 fpm	1 minute

3.5 Position Identifiers

Position identifiers have durations equal to 0.8 of the index count interval of the respective code. The leading edge of the position identifier P_0 occurs one index count interval before the frame reference point P_r and the succeeding position identifiers ($P_1, P_2 \dots P_0$) occur every succeeding tenth index count interval. The repetition rate at which the position identifiers occur is always 0.1 of the time format bit rate.

3.6 Time Code Words

The two time code words employed in this standard are:

- BCD TOY and year;
- SBS TOD (seconds-of-day).

All time code formats are pulse-width coded. A binary (1) bit has duration equal to 0.5 of the index count interval and a binary (0) bit has duration equal to 0.2 of the index count interval. The BCD TOY code reads 0 hours, minutes, seconds, and fraction of seconds at 2400 each day and reads day 001 at 2400 of day 365 or day 366 in a leap year. The year code counts year and cycles to the next year on January 1st of each year and will count to year 2099. The SBS TOD code reads 0 seconds at 2400 each day excluding leap second days when a second may be added or subtracted.

3.7 BCD Time-of-Year Code Word

The BCD TOY and year code word consists of subwords in days, hours, minutes, seconds, and year with fractions of a second in a BCD representation and TOD in SBS of day. The position identifiers preceding the decimal digits and the index count locations of the decimal digits (if present) are in [Table 3-3](#).

BCD Code Decimal Digits	Decimal Digits Follow Position Identifier	Digits Occupy Index Count Positions
Units of Seconds	P_r	1-4
Tens of Seconds		6-8
Units of Minutes	P_1	10-13
Tens of Minutes		15-17

Units of Hours	P ₂	20-23
Tens of Hours		25-26
Units of Days	P ₃	30-33
Tens of Days		35-38
Hundreds of Days	P ₄	40-41
Tenths of Seconds		45-48
For Code G	P ₅	50-53
Hundredths of Seconds		
For Codes A, B, and E	P ₅	50-53
Units of Years		55-58
Tens of Years		
For Code G	P ₆	60-63
Units of Years		
Tens of Years		

Formats A, B, and E include an optional SBS time code word in addition to a BCD TOY time and year code word. The SBS word follows position identifier P₈ beginning with the LSB (2⁰) at index count 80 and progressing to the MSB (2¹⁶) at index count 97 with a position identifier P₉ occurring between the ninth (2⁸) and tenth (2⁹) binary bits.

Formats A, B, E, and G also contain year information in a BCD format.

3.8 Control Functions

All time code formats reserve a set of CF bits for the encoding of various control, identification, and other special-purpose functions. The control bits may be programmed in any predetermined coding system. A binary 1 bit has duration equal to 0.5 of the index count interval and a binary 0 bit has duration equal to 0.2 of the index count interval. The CF bits follow position identifiers P₅, P₆, or P₇ for formats A, B, E, and G beginning at index count 50, 60, or 70 with one CF bit per index count except for each tenth bit, which is a position identifier. The number of available control bits in each time code format is shown at [Table 3-4](#).

Table 3-4. Number of Available Control Bits in Each Time Code Format	
Format	Control Function Bits
A	18
B	18
D	9
E	18
G	27
H	9

The CFs are presently intended for internal range use but not for inter-range applications; therefore, no standard coding system exists. The inclusion of CFs into a time code format as well as the coding system employed is an individual user-defined option.

3.9 Index Markers

Index markers occur at each index count position, which is not assigned as a reference marker, position identifier, data code, or CF bit. Each index marker bit has duration equal to 0.2 of the index count interval of the respective time code format.

3.10 Amplitude-Modulated Carrier

A standard sine wave carrier frequency to be amplitude-modulated by a time code is synchronized to have positive-going, zero-axis crossings coincident with the leading edges of the modulating code bits. A mark-to-space ratio of 10:3 is standard with a range of 3:1 to 6:1 (see [Figure 3-1](#) and [Table 3-5](#)).

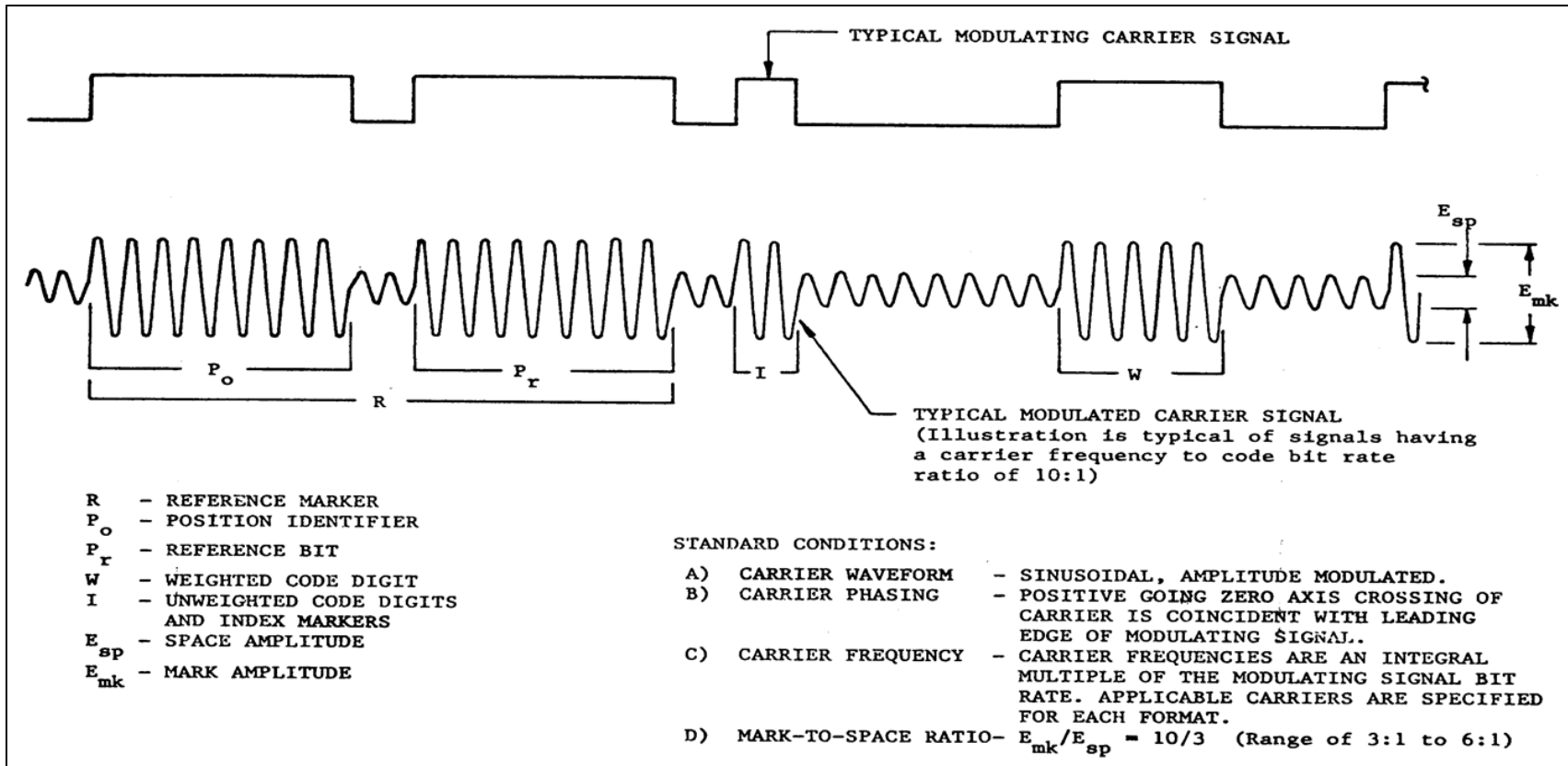

Figure 3-1. Typical Modulated Carrier Signal

Table 3-5. Typical Modulated Carrier Signal Formats for A, B, E, D, G, and H

Formats					Mark Interval Number of Cycles			
Format	Signal No.	Time Frame Rate	Carrier Frequency F	Signal Bit Rate ER	Ratio F/ER	Code "0" & Index	Code "1"	Position Identifier & Ref.
A	A 130, 132, 133, 134	10 per sec.	10 kHz	1 kpps	10:1	2	5	8
B	B 120, 122, 123, 127	1 per sec.	1 kHz	100 pps	10:1	2	5	8
D	D 111, 112, 121,122	1 per hr.	100 Hz 1 kHz	1 ppm 1 ppm	6000:1 60000:1	1200 12000	3000 30000	4800 48000
E	E 111, 112, 121,122, 125	6 per min	100 Hz 1 kHz	10 pps 10 pps	10:1 100:1	2 20	5 50	8 80
G	G 141, 142, 126	100 per sec.	100 kHz	10 kpps	10:1	2	5	8
H	H 111, 112, 121,122	1 per min.	100 Hz 1 kHz	1 pps 1 pps	100:1 1000:1	20 200	50 500	80 800

CHAPTER 4

Detailed Description of Formats

4.1 Serial Time Code Formats (A, B, D, E, and G)

The family of rate-scaled serial time code formats is designated A, B, D, E, G, and H. Various combinations of subwords and signal forms make up a time code word. To differentiate between these forms, signal identification numbers are assigned to each permissible combination (see [Figure 4-1](#)).

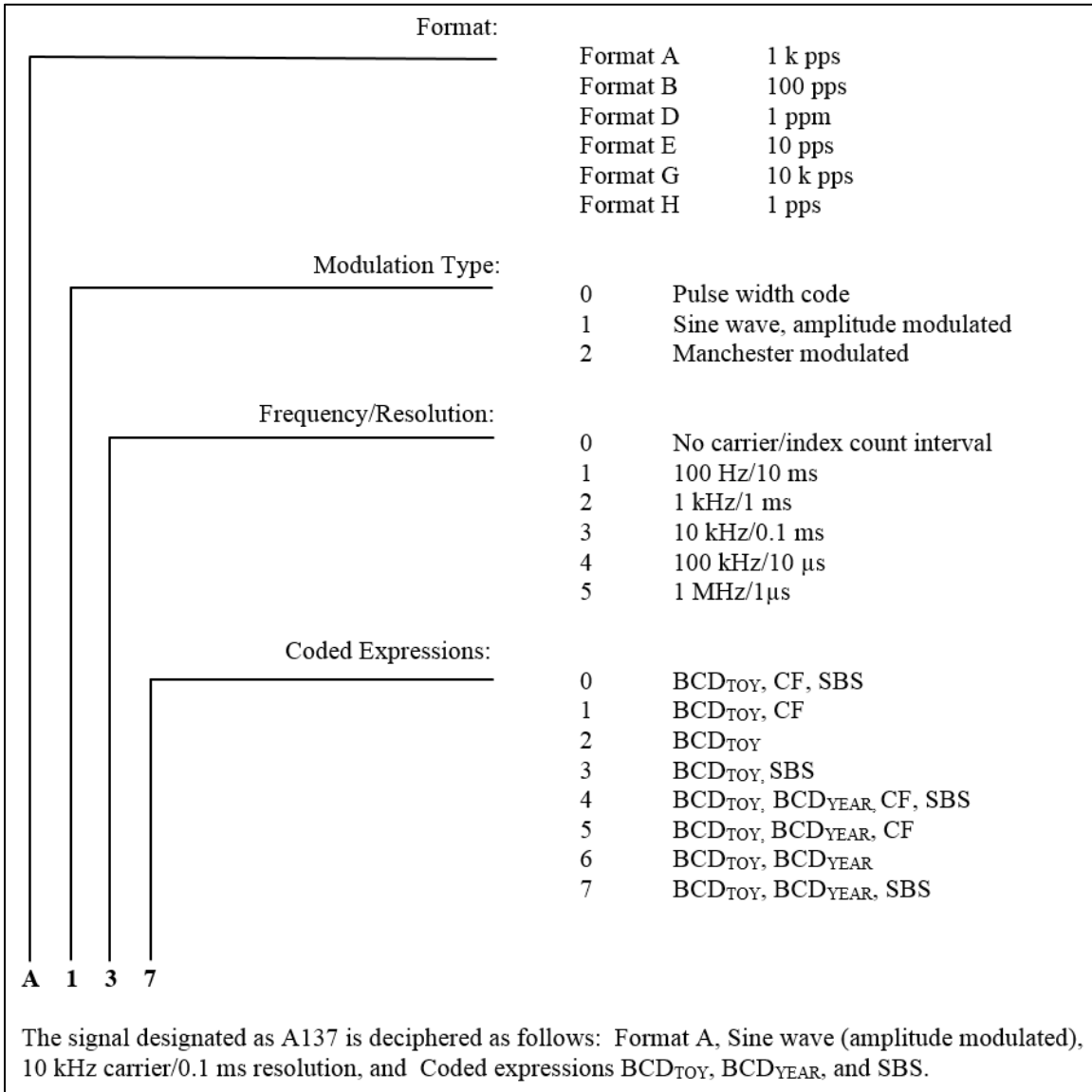

Figure 4-1. Serial Time Code Formats

The information in [Table 4-1](#) shows the permissible code formats. Codes D and H remain unchanged. Codes A, B, E, and G have changed to permit year information as indicated below. No other combinations are standard.

Table 4-1. Permissible Code Formats (A, B, D, E, G, H)			
Format	Modulation Type	Frequency/Resolution	Coded Expressions
A	0, 1, 2	0, 3, 4, 5	0, 1, 2, 3, 4, 5, 6, 7
B	0, 1, 2	0, 2, 3, 4, 5	0, 1, 2, 3, 4, 5, 6, 7
D	0, 1	0, 1, 2	1, 2
E	0, 1	0, 1, 2	1, 2, 5, 6
G	0, 1, 2	0, 4, 5	1, 2, 5, 6
H	0, 1	0, 1, 2	1, 2

The Telecommunications and Timing Group of the Range Commanders Council has adopted a Modified Manchester modulation technique as an option for the IRIG serial time codes A, B, and G as an addition to the standard AM and level shift modulation now permitted. Also, year information has been added to codes A, B, E, and G. Codes D and H remain unchanged. It should be noted that at present, the assignment of control bits (CFs) to specific functions in the IRIG serial time codes is left to the end user of the time codes.

4.2 Examples of Typical Modulated Carrier Signal Formats for IRIG A, B, E, and G

Examples are provided on the following pages as follows:

- IRIG A: [Table 4-2](#)
- IRIG B: [Table 4-3](#)
- IRIG E: [Table 4-4](#)
- IRIG G: [Table 4-5](#)

Table 4-2. Typical Modulated Carrier Signal Formats (IRIG A)	
Modified Manchester Modulations¹	
A 237	2 = Manchester modulation 3 = 10 kHz/0.1 ms 7 = BCD _{TOY} , BCD _{YEAR} , SBS
Standard AM modulations (Example Formats)	
A 130	1 = Sine wave, amplitude modulated 3 = 10 kHz/0.1 ms 0 = BCD _{TOY} , CF, SBS
A 134	1 = Sine wave, amplitude modulated 3 = 10 kHz/0.1 ms 4 = BCD _{TOY} , BCD _{YEAR} , CF, SBS
A 132	1 = Sine wave, amplitude modulated 3 = 10 kHz/0.1 ms 2 = BCD _{TOY}
A 136	1 = Sine wave, amplitude modulated 3 = 10 kHz/0.1 ms 6 = BCD _{TOY} , BCD _{YEAR}

Table 4-2. Typical Modulated Carrier Signal Formats (IRIG A)	
A 133	1 = Sine wave, amplitude modulated 3 = 10 kHz/0.1 ms 3 = BCD _{TOY} , SBS
A 137	1 = Sine wave, amplitude modulated 3 = 10 kHz/0.1ms 7 = BCD _{TOY} , BCD _{YEAR} , SBS
A 131	1 = Sine wave, amplitude modulated 3 = 10 kHz/0.1 ms 1 = BCD _{TOY} , CF
A 135	1 = Sine wave, amplitude modulated 3 = 10 kHz/0.1 ms 5 = BCD _{TOY} , BCD _{YEAR} , CF
¹ Modified Manchester modulation is an option for IRIG A in addition to the standard AM modulation in the formats in this table	

Table 4-3. Typical Modulated Carrier Signal Formats (IRIG B)	
Modified Manchester Modulations¹	
B 237	2 = Manchester modulation 3 = 10 kHz/0.1 ms 7 = BCD _{TOY} , BCD _{YEAR} , SBS
Standard AM modulations (Example Formats)	
B 120	1 = Sine wave, amplitude modulated 2 = 1 kHz/1 ms 0 = BCD _{TOY} , CF, SBS
B 124	1 = Sine wave, amplitude modulated 2 = 1 kHz/1 ms 4 = BCD _{TOY} , BCD _{YEAR} , CF, SBS
B 121	1 = Sine wave, amplitude modulated 2 = 1 kHz/1 ms 1 = BCD _{TOY} , CF
B 125	1 = Sine wave, amplitude modulated 2 = 1 kHz/1 ms 5 = BCD _{TOY} , BCD _{YEAR} , CF
B 122	1 = Sine wave, amplitude modulated 2 = 1 kHz/1 ms 2 = BCD _{TOY}
B 126	1 = Sine wave, amplitude modulated 2 = 1 kHz/1 ms 6 = BCD _{TOY} , BCD _{YEAR}
B 123	1 = Sine wave, amplitude modulated 2 = 1 kHz/1 ms 3 = BCD _{TOY} SBS

Table 4-3. Typical Modulated Carrier Signal Formats (IRIG B)	
B 127	1 = Sine wave, amplitude modulated 2 = 1 kHz/1 ms 7 = BCD _{TOY} , BCD _{YEAR} , SBS
¹ Modified Manchester modulation is an option for IRIG B in addition to the standard AM modulation in the formats in this table.	

Table 4-4. Typical Modulated Carrier Signal Formats (IRIG E)	
Standard AM modulations (Example Formats)	
E 111	1 = Sine wave, amplitude modulated 1 = 100 Hz/10 ms 1 = BCD _{TOY} , CF
E 115	1 = Sine wave, amplitude modulated 1 = 100 Hz/10 ms 5 = BCD _{TOY} , BCD _{YEAR} , CF
E 112	1 = Sine wave, amplitude modulated 1 = 100 Hz/10 ms 2 = BCD _{TOY} ,
E 116	1 = Sine wave, amplitude modulated 1 = 100 Hz/10 ms 6 = BCD _{TOY} , BCD _{YEAR}
E 121	1 = Sine wave, amplitude modulated 2 = 1 kHz/1 ms 1 = BCD _{TOY} , CF
E 125	1 = Sine wave, amplitude modulated 2 = 1 kHz/1 ms 5 = BCD _{TOY} , BCD _{YEAR} , CF
E 122	1 = Sine wave, amplitude modulated 2 = 1 kHz/1 ms 2 = BCD _{TOY}
E 126	1 = Sine wave, amplitude modulated 2 = 1 kHz/1ms 6 = BCD _{TOY} , BCD _{YEAR}

Table 4-5. Typical Modulated Carrier Signal Formats (IRIG G)	
Modified Manchester Modulations¹	
G 245	2 = Manchester modulation 4 = 100 kHz/10 μ s 5 = BCD _{TOY} , BCD _{YEAR} , CF
Standard AM modulations (Example Formats)	
G 141	1 = Sign wave, amplitude modulation 4 = 100 kHz/10 μ s 1 = BCD _{TOY} , CF

Table 4-5. Typical Modulated Carrier Signal Formats (IRIG G)	
G 145	1 = Sign wave, amplitude modulation 4 = 100 kHz/10 μ s 5 = BCD _{TOY} , BCD _{YEAR} , CF
G 142	1 = Sign wave, amplitude modulated 4 = 100 kHz/10 μ s 2 = BCD _{TOY}
G 146	1 = Sign wave, amplitude modulated 4 = 100 kHz/10 μ s 6 = BCD _{TOY} , BCD _{YEAR}
¹ Modified Manchester modulation is an option for IRIG G in addition to the standard AM modulation in the formats in this table.	

4.3 Manchester II Coding

Standard Manchester modulation or encoding is a return-to-zero type, where a rising edge in the middle of the clock window indicates a binary 1 and a falling edge indicates a binary 0. This modification to the Manchester code shifts the data window so the data are at the edge of the clock window that is on time with the one-pps clock synchronized to UTC. Thus, the data edge is the on-time mark in the code. Manchester coding is used because it is easy to generate digitally, easily modulated for use over fiber or coaxial cable, simple to decode, has a zero mean, and is easily detected even at low voltage levels.

The basic Modified Manchester modulation, compared with the AM and level shift modulations, are shown at [Figure 4-2](#) and [Figure 4-3](#). The Manchester encoding uses a square-wave as the encoding (data) clock, with the rising edge on time with UTC. The frequency of the encoding clock shall be ten times the index rate of the time code generated. As an example, the clock rate for IRIG B 230 shall be 10 kHz.

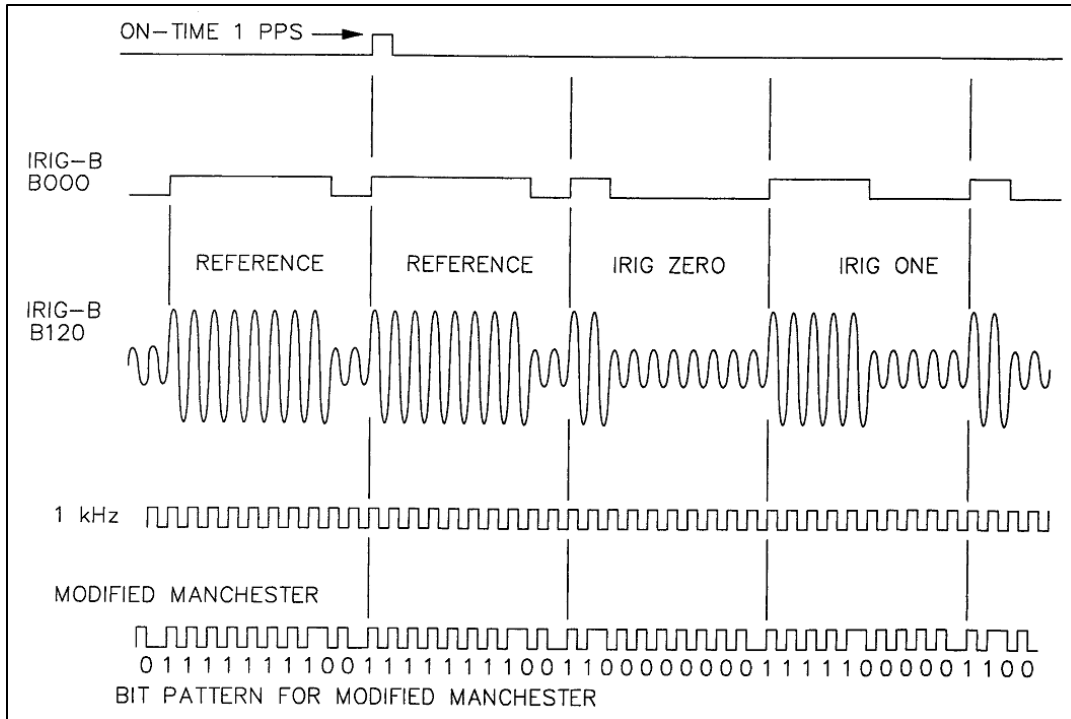

Figure 4-2. IRIG B Coding Comparisons: Level Shift, 1 kHz am, and Modified Manchester

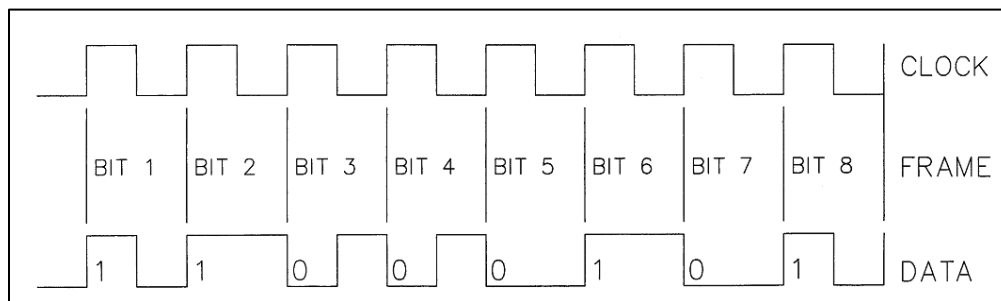

Figure 4-3. Modified Manchester Coding

The Modified Manchester coding technique has several advantages as noted below.

- No dc component.
- Can be alternating current coupled.
- Better signal-to-noise ratio.
- Good spectral power density.
- Easily decoded.
- Better timing resolution.
- The link integrity monitoring capability is intrinsic to bipolar pulse modulation.
- The coding technique is designed to operate over fiber-optic or coaxial lines for short distances.

4.4 Manchester II Decoding

An example of a Manchester II encoded sequence is shown at [Figure 4-4](#), where each symbol is “sub-bit” encoded, i.e., a data one equals a zero-one, and a data zero equals a one-zero.

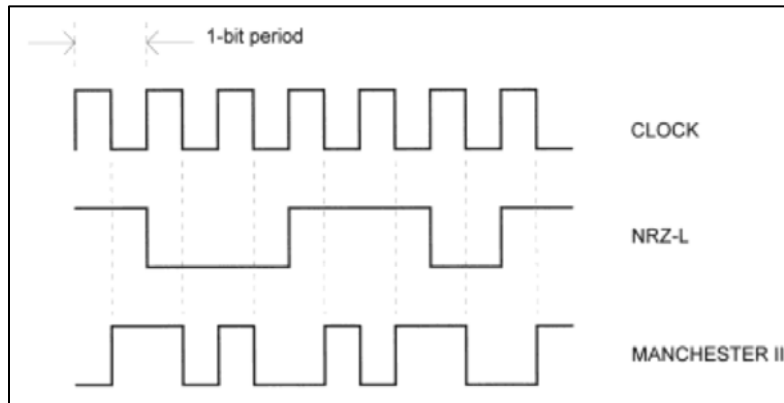

Figure 4-4. A Manchester II Encoded Sequence

The encoded sequence at [Figure 4-4](#) is formed by modulo-2 adding the non-return-to-zero level (NRZ-L) sequence with the clock. The truth table shown in [Table 4-6](#) is for a modulo-2 adder, which is equivalent to an Exclusive-OR.

Input A	Input B	Output
0	0	0
0	1	1
1	0	1
1	1	0

To decode the encoded sequence of [Figure 4-4](#), it is only necessary to modulo-2 add the clock with the encoded sequence and the original NRZ-L sequence results. It should be noted that the determination is made after integrating across a bit period. In this way, the maximum amount of energy is used in the determination of each bit. Likewise, an engineer could have integrated or sampled both halves of the encoded sequence and reconstructed the original NRZ-L sequence by applying the encoding rule. This means that if sampled halves are 0-1, then a data 1 is reconstructed, and if the sampled halves are 1-0, then a data 0 is reconstructed. Once again, as much energy as possible is used from the encoded sequence to reconstruct the original NRZ-L sequence. This procedure minimizes the probability of error.

NOTE



When the above procedure is used, the reconstructed data are coherent with the clock; that is, the NRZ-L data transitions will agree with the positive going edge of the clock; however, since the decisions are made at the end of the symbol period, the reconstructed NRZ-L data are delayed one clock period. This means that when the entire time is received, the received time code or local clock needs to be advanced by one clock period. Also, if desired, one can correct the receive clock for significant signal propagation delays.

This page intentionally left blank.

CHAPTER 5

Detailed Description of Time Codes

5.1 Introduction

Detailed descriptions of individual time code formats are shown in the following paragraphs.

5.2 Format A

The following is a detailed description of IRIG time code format A.

- The beginning of each 0.1-second time frame is identified by two consecutive 0.8-ms bits, P_0 and P_r . The leading edge of P_r is the on-time reference point for the succeeding time code words. Position identifiers, P_0 and P_1 through P_9 , (0.8 ms duration), each use 1 ms of the time frame (which is one full index count duration), and occur every tenth bit and 1 ms before the leading edge of each succeeding 100-pps on-time bit (see [Figure 5-1](#)).
- The three time code words and the CFs presented during the time frame are pulse-width coded. The time code bit rate is 1 kpps. The time code reference bit's leading edge is the on-time reference point for all bits and is the index count reference point. The binary 0 and index markers have duration of 0.2 ms and the binary 1 has duration of 0.5 ms.
- The BCD TOY coded word consists of 34 bits beginning at index count 1. The TOY subword bits occur between position identifiers P_0 and P_5 : 7 bits for seconds, 7 for minutes, 6 for hours, 10 for days, and 4 for tenths of seconds. Year information, coded in 8 bits, occur between position identifiers P_5 and P_6 to complete the BCD time code word. An index marker occurs between the decimal digits in each subword, except tenths of seconds, to provide separation for visual resolution. The LSB occurs first except for the fractional seconds subword that follows the day-of-year subword. The BCD TOY code recycles yearly.
- There are 18 CFs occur between position identifiers P_6 and P_8 . Any CF bit or combination of bits can be programmed to read a binary 1 or a binary 0 during any specified number of frames. Each control bit position is identified in [Table 5-1](#).
- The SBS TOD code word occurs at index count 80 between position identifiers P_8 and P_0 . The time of day in seconds is given in 17 bits with the LSB occurring first. A position identifier P_9 occurs between the ninth and tenth binary seconds. The code recycles each 24-hour period.
- Control bit assignments, functions, and parameters for time code format A are shown on the following pages.

[Table 5-2](#): Identifies the control bit assignments for year information.

[Table 5-3](#): Identifies the parameters that characterize the time code for Format A.

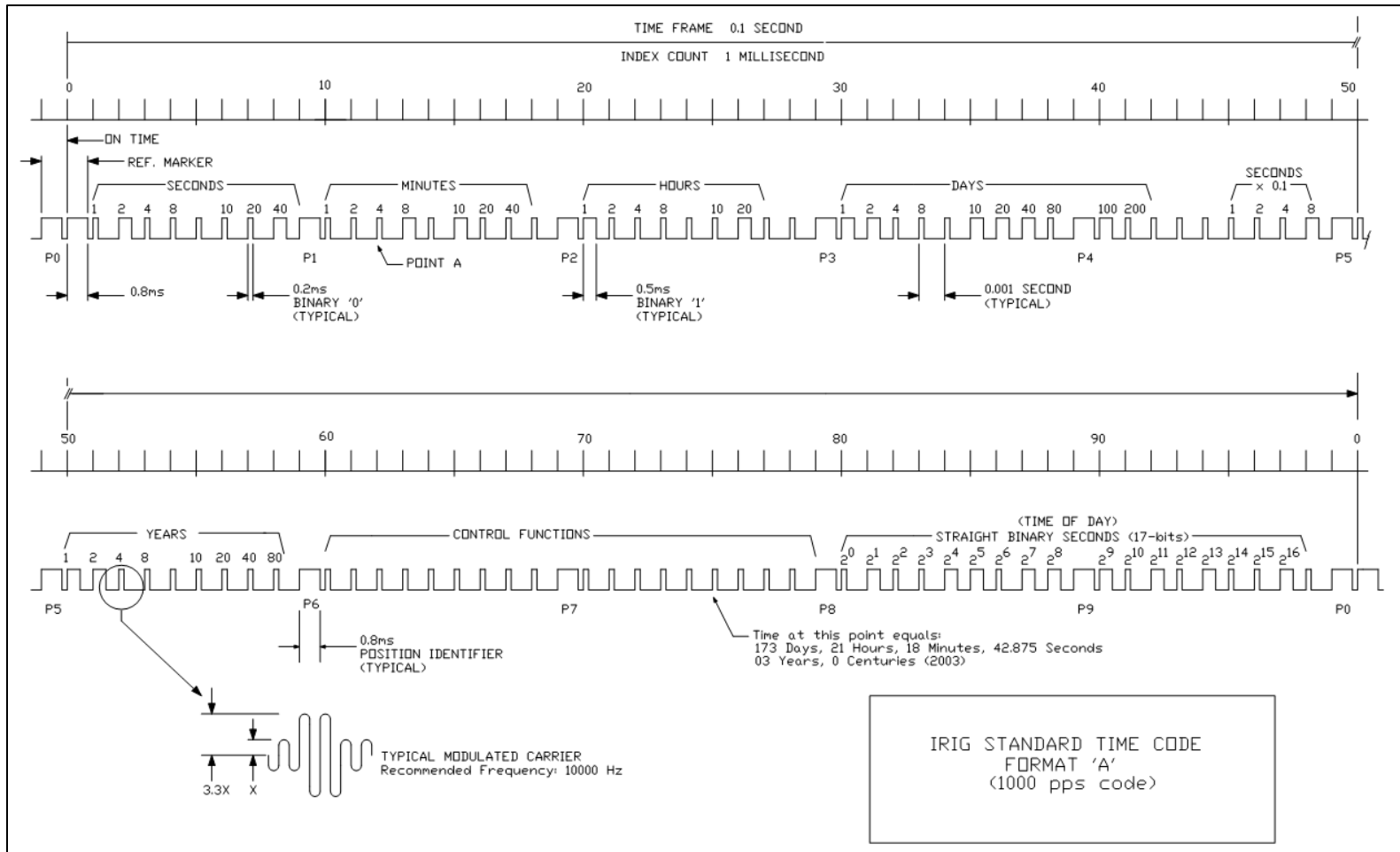

Figure 5-1. Format A: BCD Time-of-Year in Days, Hours, Minutes, Seconds, Fractions of Seconds, Year, Straight Binary Seconds Time-of-Day, and Control Bits

Table 5-1. Format A, Signal A000

BCD Time-of-Year Code (34 Digits)														
Seconds Subword			Minutes Subword			Hours Subword			Days And Fractional Second Subwords					
BCD Code Digit No.	Subword Digit Wt Seconds	Bit Time ¹	BCD Code Digit No.	Subword Digit Wt Minutes	Bit Time	BCD Code Digit No.	Subword Digit Wt Hours	Bit Time	BCD Code Digit No.	Subword Digit Wt Days	Bit Time	BCD Code Digit No.	Subword Digit Wt Days	Bit Time
Reference Bit		P _r	8	1	P _r + 10 ms	15	1	P _r + 20 ms	21	1	P _r + 30 ms	29	100	P _r + 40 ms
1	1	P _r + 1 ms	9	2	P _r + 11 ms	16	2	P _r + 21 ms	22	2	P _r + 31 ms	30	200	P _r + 41 ms
2	2	P _r + 2 ms	10	4	P _r + 12 ms	17	4	P _r + 22 ms	23	4	P _r + 32 ms	Index Bit		P _r + 42 ms
3	4	P _r + 3 ms	11	8	P _r + 13 ms	18	8	P _r + 23 ms	24	8	P _r + 33 ms	Index Bit		P _r + 43 ms
4	8	P _r + 4 ms	Index Bit		P _r + 14 ms	Index Bit		P _r + 24 ms	Index Bit		P _r + 34 ms	Index Bit		P _r + 44 ms
Index Bit		P _r + 5 ms	12	10	P _r + 15 ms	19	10	P _r + 25 ms	25	10	P _r + 35 ms	31	0.1	P _r + 45 ms
5	10	P _r + 6 ms	13	20	P _r + 16 ms	20	20	P _r + 26 ms	26	20	P _r + 36 ms	32	0.2	P _r + 46 ms
6	20	P _r + 7 ms	14	40	P _r + 17 ms	Index Bit		P _r + 27 ms	27	40	P _r + 37 ms	33	0.4	P _r + 47 ms
7	40	P _r + 8 ms	Index Bit		P _r + 18 ms	Index Bit		P _r + 28 ms	28	80	P _r + 38 ms	34	0.8	P _r + 48 ms
Position Ident. (P ₁)		P _r + 9 ms	Position Ident. (P ₂)		P _r + 19 ms	Position Ident. (P ₃)		P _r + 29 ms	Position Ident. (P ₄)		P _r + 39 ms	Position Ident. (P ₅)		P _r + 49 ms
Year and Control Functions (27 Bits)						Straight Binary Seconds Time-of-Day Code (17 Digits)								
Control Function Bit	Bit Time	Control Function Bit	Bit Time	Control Function Bit	Bit Time	SB Code Bit	Subword Digit Weight	Bit Time	SB Code Bit	Subword Digit Weight	Bit Time			
1	P _r + 50 ms Units of Year 01	1	P _r + 60 ms	10	P _r + 70 ms	1	2 ⁰ = (1)	P _r + 80 ms	10	2 ⁹ = (512)	P _r + 90 ms			
2	Units of Year 02	2	P _r + 61 ms	11	P _r + 71 ms	2	2 ¹ = (2)	P _r + 81 ms	11	2 ¹⁰ = (1024)	P _r + 91 ms			
3	Units of Year 04	3	P _r + 62 ms	12	P _r + 72 ms	3	2 ² = (4)	P _r + 82 ms	12	2 ¹¹ = (2048)	P _r + 92 ms			
4	Units of Year 08	4	P _r + 63 ms	13	P _r + 73 ms	4	2 ³ = (8)	P _r + 83 ms	13	2 ¹² = (4096)	P _r + 93 ms			
Index Mark	P _r + 54 ms	5	P _r + 64 ms	14	P _r + 74 ms	5	2 ⁴ = (16)	P _r + 84 ms	14	2 ¹³ = (8192)	P _r + 94 ms			
5	Tens of Year 10	6	P _r + 65 ms	15	P _r + 75 ms	6	2 ⁵ = (32)	P _r + 85 ms	15	2 ¹⁴ = (16384)	P _r + 95 ms			
6	Tens of Year 20	7	P _r + 66 ms	16	P _r + 76 ms	7	2 ⁶ = (64)	P _r + 86 ms	16	2 ¹⁵ = (32768)	P _r + 96 ms			
7	Tens of Year 40	8	P _r + 67 ms	17	P _r + 77 ms	8	2 ⁷ = (128)	P _r + 87 ms	17	2 ¹⁶ = (65536)	P _r + 97 ms			
8	Tens of Year 80	9	P _r + 68 ms	18	P _r + 78 ms	9	2 ⁸ = (256)	P _r + 88 ms	Index Bit		P _r + 98 ms			
Position Ident. (P ₆)	P _r + 59 ms	Position Ident. (P ₇)	P _r + 69 ms	Position Ident. (P ₈)	P _r + 79 ms	Position Ident. (P ₉)		P _r + 89 ms	Position Ident. (P ₀)		P _r + 99 ms			

¹The bit time is the time of the bit leading edge and refers to the leading edge of P_r.

Table 5-2. IRIG-A Control Bit Assignment for Year Information			
Pos. Id	Ctrl Bit No	Designation	Explanation
P ₀ to P ₅ is BCD TOY in seconds, minutes, hours, days, and fractional seconds.			
P ₄₉	--	P ₅	Position Identifier #5
P ₅₀	Year 1	Year, BCD 1	LSB 2 digits of year in BCD
P ₅₁	Year 2	Year, BCD 2	IBID
P ₅₂	Year 3	Year, BCD 4	IBID
P ₅₃	Year 4	Year, BCD 8	IBID
P ₅₄	--	Not Used	Index Marker
P ₅₅	Year 6	Year, BCD 10	MSB 2 digits of year in BCD
P ₅₆	Year 7	Year, BCD 20	IBID
P ₅₇	Year 8	Year, BCD 40	IBID
P ₅₈	Year 9	Year, BCD 80	IBID
P ₅₉	--	P ₆	Position Identifier #6
P ₆₀	1	Not Used	Control Bit
P ₆₁	2	IBID	IBID
P ₆₂	3	IBID	IBID
P ₆₃	4	IBID	IBID
P ₆₄	5	IBID	IBID
P ₆₅	6	IBID	IBID
P ₆₆	7	IBID	IBID
P ₆₇	8	IBID	IBID
P ₆₈	9	IBID	IBID
P ₆₉	--	P ₇	Position Identifier #7
P ₇₀	10	Not Used	Control Bit
P ₇₁	11	IBID	IBID
P ₇₂	12	IBID	IBID
P ₇₃	13	IBID	IBID
P ₇₄	14	IBID	IBID
P ₇₅	15	IBID	IBID
P ₇₆	16	IBID	IBID
P ₇₇	17	IBID	IBID
P ₇₈	18	IBID	IBID
P ₇₉	--	P ₈	Position Identifier #8
P ₆ to P ₈ are control functions			
P ₈ to P ₀ is TOD in straight binary seconds.			

Table 5-3. Parameters for Format A	
Pulse Rates	Pulse Duration
Bit rate: 1 kpps Position identifier rate: 100 pps Reference marker: 10 pps	Index marker: 0.2 ms Binary 0 or un-encoded bit: 0.2 ms Binary 1 or coded bit: 0.5 ms Position identifiers: 0.8 ms Reference bit: 0.8 ms
Resolution	Mark-To-Space Ratio
1 ms dc level 0.1 ms modulated 10 kHz carrier	Nominal value of 10:3 Range of 3:1 to 6:1

5.3 Format B

The following is a detailed description of IRIG time code format B.

- The beginning of each 1.0-second time frame is identified by two consecutive 8.0-ms bits, P_0 and P_r . The leading edge of P_r is the on-time reference point for the succeeding time code words. Position identifiers, P_0 and P_1 through P_9 each use 10 ms of the time frame, one full index count duration. Position identifiers occur every 10 ms before the leading edge of each succeeding tenth index count (see [Figure 5-2](#)).
- The three time code words and the CFs presented during the time frame are pulse-width coded. The time code bit rate is 100 pps. The time code reference bit's leading edge is the on-time reference point for all bits and is the index count reference point. The binary 0 and the index markers have duration of 2.0 ms and a binary 1 has duration of 5.0 ms.
- The BCD TOY code word consists of 30 bits beginning at index count 1. The subword bits occur between position identifiers P_0 and P_5 ; there are 7 bits for seconds, 7 for minutes, 6 for hours, and 10 for days. Additionally, there are 17 SBS bits. Year information is coded in 8 bits occurring between position identifiers P_5 and P_6 to complete the BCD time code word. An index marker occurs between the decimal digits in each subword to provide separation for visual resolution. The LSB occurs first. The BCD TOY code recycles yearly. Each bit position is identified in [Table 5-4](#).
- There are 18 CFs occurring between position identifiers P_6 and P_8 . Any CF bit or combination of bits can be programmed to read a binary 1 or 0 during any specified number of time frames.
- The SBS TOD word begins at index count 80 and occurs between position identifiers P_8 and P_0 . A position identifier occurs between the ninth and tenth binary coded bit. The code recycles each 24-hour period.
- Control bit assignments, functions, and parameters for time code format B are shown on the following pages.

[Table 5-5](#): Identifies the control bit assignments for year information.

[Table 5-6](#): Identifies the parameters that characterize the time code for Format B.

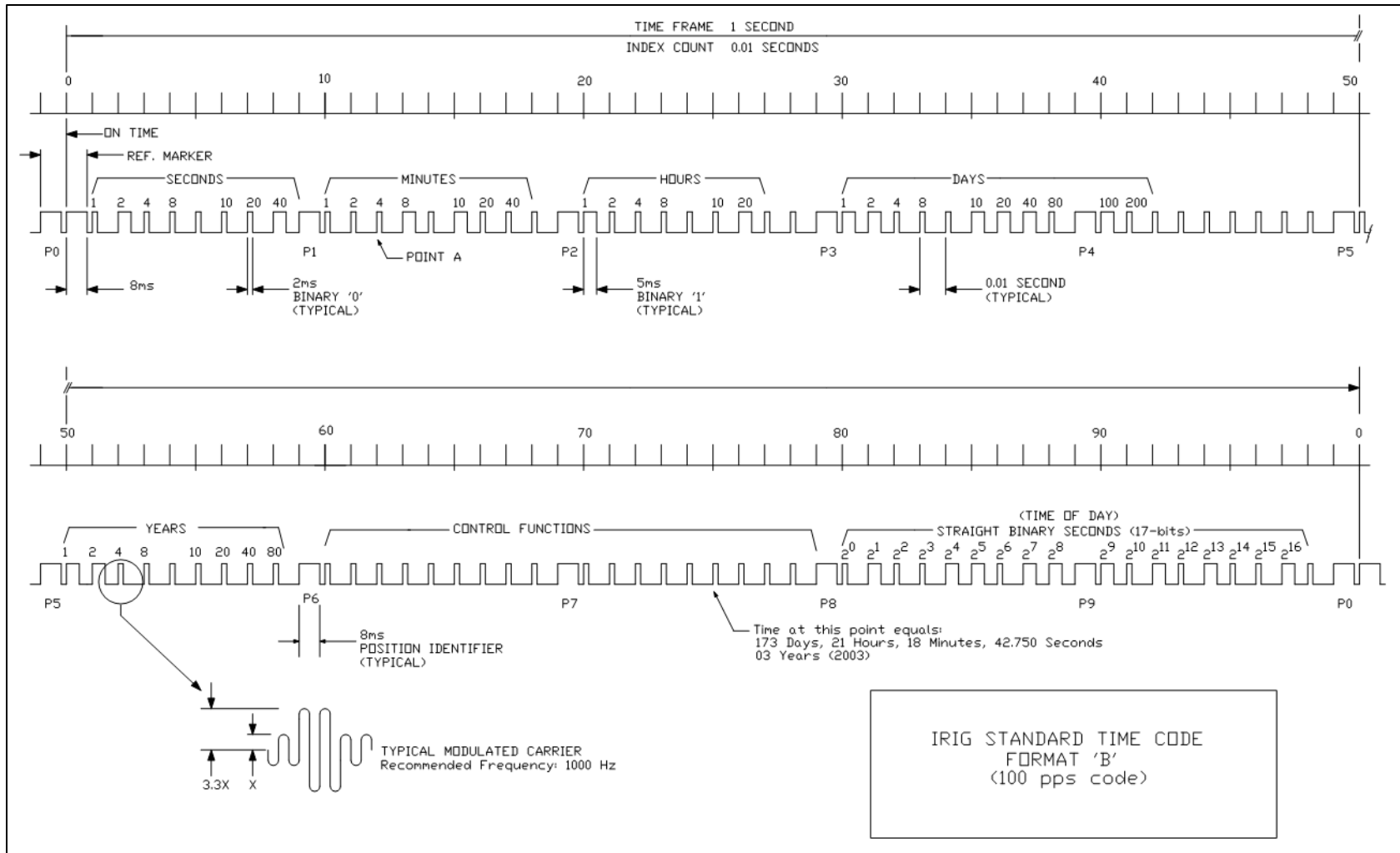

Figure 5-2. Format B: BCD Time-of-Year in Days, Hours, Minutes, Seconds, Year, Straight Binary Seconds Time-of-Day, and Control Bits.

Table 5-4. Format B, Signal B000

BCD Time-of-Year Code (30 Digits)														
Seconds Subword			Minutes Subword			Hours Subword			Days Subword					
BCD Code Digit No.	Subword Digit Wt Seconds	Bit Time ¹	BCD Code Digit No.	Subword Digit Wt Minutes	Bit Time	BCD Code Digit No.	Subword Digit Wt Hours	Bit Time	BCD Code Digit No.	Subword Digit Wt Days	Bit Time	BCD Code Digit No.	Subword Digit Wt Days	Bit Time
Reference Bit		P _r	8	1	P _r + 100 ms	15	1	P _r + 200 ms	21	1	P _r + 300 ms	29	100	P _r + 400 ms
1	1	P _r + 10 ms	9	2	P _r + 110 ms	16	2	P _r + 210 ms	22	2	P _r + 310 ms	30	200	P _r + 410 ms
2	2	P _r + 20 ms	10	4	P _r + 120 ms	17	4	P _r + 220 ms	23	4	P _r + 320 ms	Index Bit		P _r + 420 ms
3	4	P _r + 30 ms	11	8	P _r + 130 ms	18	8	P _r + 230 ms	24	8	P _r + 330 ms	Index Bit		P _r + 430 ms
4	8	P _r + 40 ms	Index Bit		P _r + 140 ms	Index Bit		P _r + 240 ms	Index Bit		P _r + 340 ms	Index Bit		P _r + 440 ms
Index Bit		P _r + 50 ms	12	10	P _r + 150 ms	19	10	P _r + 250 ms	25	10	P _r + 350 ms	Index Bit		P _r + 450 ms
5	10	P _r + 60 ms	13	20	P _r + 160 ms	20	20	P _r + 260 ms	26	20	P _r + 360 ms	Index Bit		P _r + 460 ms
6	20	P _r + 70 ms	14	40	P _r + 170 ms	Index Bit		P _r + 270 ms	27	40	P _r + 370 ms	Index Bit		P _r + 470 ms
7	40	P _r + 80 ms	Index Bit		P _r + 180 ms	Index Bit		P _r + 280 ms	28	80	P _r + 380 ms	Index Bit		P _r + 480 ms
Position Ident. (P ₁)		P _r + 90 ms	Position Ident. (P ₂)		P _r + 190 ms	Position Ident. (P ₃)		P _r + 290 ms	Position Ident. (P ₄)		P _r + 390 ms	Position Ident. (P ₅)		P _r + 490 ms
Year and Control Functions (27 Bits)									Straight Binary Seconds Time-of-Day Code (17 Digits)					
Control Function Bit	Bit Time	Control Function Bit	Bit Time	Control Function Bit	Bit Time	SB Code Bit	Subword Digit Weight	Bit Time	SB Code Bit	Subword Digit Weight	Bit Time	SB Code Bit	Subword Digit Weight	Bit Time
1	P _r + 500 ms Units of Year 01	1	P _r + 600 ms	10	P _r + 700 ms	1	2 ⁹ = (1)	P _r + 800 ms	10	2 ⁹ = (512)	P _r + 900 ms			
2	Units of Year 02	2	P _r + 610 ms	11	P _r + 710 ms	2	2 ¹ = (2)	P _r + 810 ms	11	2 ¹⁰ = (1024)	P _r + 910 ms			
3	Units of Year 04	3	P _r + 620 ms	12	P _r + 720 ms	3	2 ² = (4)	P _r + 820 ms	12	2 ¹¹ = (2048)	P _r + 920 ms			
4	Units of Year 08	4	P _r + 630 ms	13	P _r + 730 ms	4	2 ³ = (8)	P _r + 830 ms	13	2 ¹² = (4096)	P _r + 930 ms			
Index Mark	P _r + 540 ms	5	P _r + 640 ms	14	P _r + 740 ms	5	2 ⁴ = (16)	P _r + 840 ms	14	2 ¹³ = (8192)	P _r + 940 ms			
5	Tens of Year 10	6	P _r + 650 ms	15	P _r + 750 ms	6	2 ⁵ = (32)	P _r + 850 ms	15	2 ¹⁴ = (16384)	P _r + 950 ms			
6	Tens of Year 20	7	P _r + 660 ms	16	P _r + 760 ms	7	2 ⁶ = (64)	P _r + 860 ms	16	2 ¹⁵ = (32768)	P _r + 960 ms			
7	Tens of Year 40	8	P _r + 670 ms	17	P _r + 770 ms	8	2 ⁷ = (128)	P _r + 870 ms	17	2 ¹⁶ = (65536)	P _r + 970 ms			
8	Tens of Year 80	9	P _r + 680 ms	18	P _r + 780 ms	9	2 ⁸ = (256)	P _r + 880 ms	Index Bit		P _r + 980 ms			
Position Ident. (P ₆)	P _r + 590 ms	Position Ident. (P ₇)	P _r + 690 ms	Position Ident. (P ₈)	P _r + 790 ms	Position Ident. (P ₉)		P _r + 890 ms	Position Ident. (P ₀)		P _r + 990 ms			

¹The bit time is the time of the bit leading edge and refers to the leading edge of P_r.

Table 5-5. IRIG-B Control Bit Assignment for Year Information			
Pos. ID	Ctrl Bit No	Designation	Explanation
P ₀ to P ₅ is BCD TOY in seconds, minutes, hours, and days.			
P ₄₉	--	P ₅	Position Identifier #5
P ₅₀	Year 1	Year, BCD 1	Last 2 digits of year in BCD
P ₅₁	Year 2	Year, BCD 2	IBID
P ₅₂	Year 3	Year, BCD 4	IBID
P ₅₃	Year 4	Year, BCD 8	IBID
P ₅₄	--	Not Used	Unassigned
P ₅₅	Year 5	Year, BCD 10	Last 2 digits of year in BCD
P ₅₆	Year 6	Year, BCD 20	IBID
P ₅₇	Year 7	Year, BCD 20	IBID
P ₅₈	Year 8	Year, BCD 20	IBID
P ₅₉	--	P ₆	Position Identifier #6
P ₆₀	1	Not Used	Control Bit
P ₆₁	2	IBID	IBID
P ₆₂	3	IBID	IBID
P ₆₃	4	IBID	IBID
P ₆₄	5	IBID	IBID
P ₆₅	6	IBID	IBID
P ₆₆	7	IBID	IBID
P ₆₇	8	IBID	IBID
P ₆₈	9	IBID	IBID
P ₆₉	--	P ₇	Position Identifier #7
P ₇₀	10	Not Used	Control Bit
P ₇₁	11	IBID	IBID
P ₇₂	12	IBID	IBID
P ₇₃	13	IBID	IBID
P ₇₄	14	IBID	IBID
P ₇₅	15	IBID	IBID
P ₇₆	16	IBID	IBID
P ₇₇	17	IBID	IBID
P ₇₈	18	IBID	IBID
P ₇₉	--	P ₈	Position Identifier #8
P ₆ to P ₈ are control functions			
P ₈ to P ₀ is TOD in SBS.			

Table 5-6. Parameters for Format B	
Pulse Rates	Pulse Duration
Bit rate: 100 pps Position identifier: 10 pps Reference mark: 1 pps	Index marker: 2 ms Binary 0 or un-encoded bit: 2 ms Binary 1 or coded bit: 5 ms Position identifiers: 8 ms Reference bit: 8 ms
Resolution	Mark-To-Space Ratio
10 ms dc level 1 ms modulated 1 kHz carrier	Nominal value of 10:3 Range of 3:1 to 6:1

5.4 Format D

The following is a detailed description of IRIG time code format D.

- The beginning of each 1-hour time frame is identified by two consecutive 48-second bits, P_0 and P_r . The leading edge of P_r is the on-time point for the succeeding time code word. Position identifiers P_0 and P_1 through P_5 each use 1 minute of the time frame, one full index count duration. Position identifiers occur every minute before the leading edge of each succeeding tenth index count (see [Figure 5-3](#)).
- The time code word and the control bits presented during the time frame are pulse-width coded. The time code bit rate is 1 ppm. The time code reference bit's leading edge is the on-time reference point for all bits and is the index count reference point. The binary 0 and the index markers each have duration of 12 seconds and the binary 1 has duration of 30 seconds.
- The BCD TOY code consists of 16 bits beginning at index count 20. The subword bits occur between position identifiers P_2 and P_5 : 6 bits for hours and 10 bits for days to complete the time code word. An index marker occurs between the decimal digits in each subword to provide separation for visual resolution. The LSB occurs first. The code recycles yearly. Each bit position is identified in [Table 5-7](#).
- Nine control bits occur between position identifiers P_5 and P_0 . Any CF bit or combination of bits can be programmed to read a binary 1 or 0 during any specified number of time frames.
- Details of the parameters that characterize the time code for format D are shown in [Table 5-8](#).

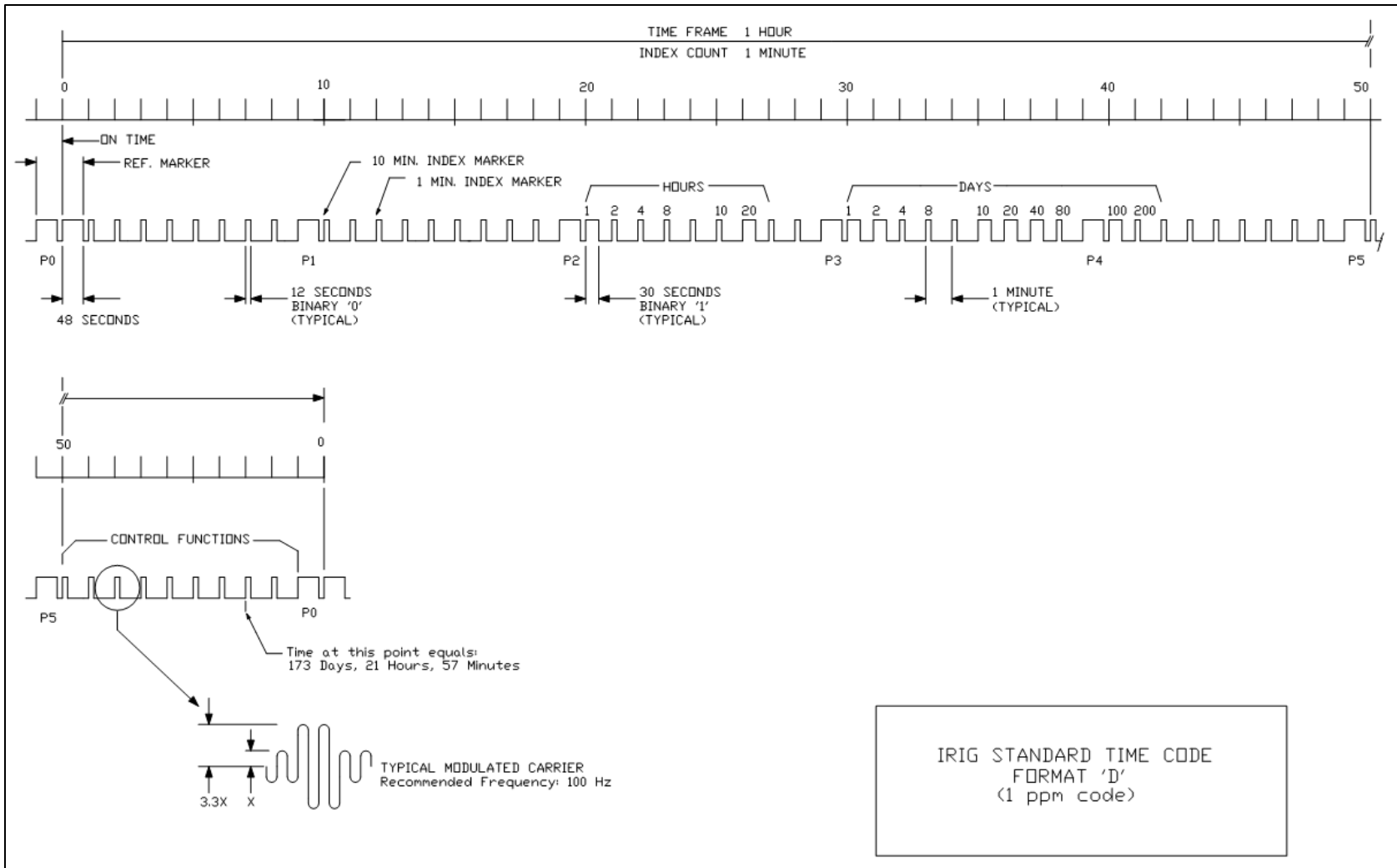

Figure 5-3. Format D: BCD Time-of-Year in Days and Hours and Control Bits

Table 5-7. Format D, Signal D001

BCD Time-of-Year Code (16 Digits)								
Minutes Subword						Hours Subword		
BCD Code Digit No.	Subword Digit Wt Minutes	Bit Time ¹	BCD Code Digit No.	Subword Digit Wt Minutes	Bit Time	BCD Code Digit No.	Subword Digit Wt Hours	Bit Time
	Reference Bit	P _r		Index Marker	P _r + 10 min	1	1	P _r + 20 min
	Index Marker	P _r + 1 min		Index Marker	P _r + 11 min	2	2	P _r + 21 min
	Index Marker	P _r + 2 min		Index Marker	P _r + 12 min	3	4	P _r + 22 min
	Index Marker	P _r + 3 min		Index Marker	P _r + 13 min	4	8	P _r + 23 min
	Index Marker	P _r + 4 min		Index Marker	P _r + 14 min	Index Marker		P _r + 24 min
	Index Marker	P _r + 5 min		Index Marker	P _r + 15 min	5	10	P _r + 25 min
	Index Marker	P _r + 6 min		Index Marker	P _r + 16 min	6	20	P _r + 26 min
	Index Marker	P _r + 7 min		Index Marker	P _r + 17 min	Index Marker		P _r + 27 min
	Index Marker	P _r + 8 min		Index Marker	P _r + 18 min	Index Marker		P _r + 28 min
	Position Ident. (P _i)	P _r + 9 min		Position Ident. (P ₂)	P _r + 19 min	Position Ident. (P ₃)		P _r + 29 min
Days Subword						Control Functions (9 Bits)		
BCD Code Digit No.	Subword Digit Wt Days	Bit Time	BCD Code Digit No.	Subword Digit Wt Days	Bit Time	Control Function Bit		Bit Time
7	1	P _r + 30 min	15	100	P _r + 40 min	1		P _r + 50 min
8	2	P _r + 31 min	16	200	P _r + 41 min	2		P _r + 51 min
9	4	P _r + 32 min	Index Marker		P _r + 42 min	3		P _r + 52 min
10	8	P _r + 33 min	Index Marker		P _r + 43 min	4		P _r + 53 min
Index Bit		P _r + 34 min	Index Marker		P _r + 44 min	5		P _r + 54 min
11	10	P _r + 35 min	Index Marker		P _r + 45 min	6		P _r + 55 min
12	20	P _r + 36 min	Index Marker		P _r + 46 min	7		P _r + 56 min
13	40	P _r + 37 min	Index Marker		P _r + 47 min	8		P _r + 57 min
14	80	P _r + 38 min	Index Marker		P _r + 48 min	9		P _r + 58 min
Position Ident. (P ₄)		P _r + 39 min	Position Ident. (P ₅)		P _r + 49 min	Position Ident. (P ₀)		P _r + 59 min

¹The bit time is the time of the bit leading edge and refers to the leading edge of P_r.

Table 5-8. Parameters for Format D	
Pulse Rates	Pulse Duration
Bit rate: 1 ppm Position identifiers: 6 pph Reference mark: 1 pph	Index marker: 12 s Binary 0 or un-encoded bit: 12 s Binary 1 or coded bit: 30 s Position identifiers: 48 s Reference bit: 48 s
Resolution	Mark-To-Space Ratio
1 m dc level 10 ms modulated 100 Hz carrier 1 ms modulated 1 kHz carrier	Nominal value of 10:1 Range of 3:1 to 6:1

5.5 Format E

The following is a detailed description of IRIG time code format E.

- The beginning of each 10-second time frame is identified by two consecutive 80-ms bits, P_0 and P_r . The leading edge of P_r is the on-time reference point for the succeeding time code words. Position identifiers P_0 and P_1 through P_9 each use 100 ms of the time frame, one full index count duration. Position identifiers occur every 0.1 second before the leading edge of each succeeding tenth index count (see [Figure 5-4](#)).
- The time code words and CFs presented during the time frame are pulse-width coded. The time code bit rate is 10 pps. The time code reference bit's leading edge is the on-time reference point for all bits and is the index count reference point. The binary 1 and index markers have duration of 20 ms and the binary 1 has duration of 50 ms.
- The BCD TOY code word consists of 26 bits beginning at index count 6. The coded subword bits occur between position identifiers P_0 and P_5 : 3 for tens of seconds, 7 for minutes, 6 for hours, and 10 for days. Year information is coded in 8 bits occurring between position identifiers P_5 and P_6 to complete the BCD time code word. An index marker occurs between the decimal digits in each subword to provide separation for visual resolution. The LSB occurs first. The code recycles yearly. Each bit position is identified in [Table 5-9](#).
- There are 18 CF bits occurring between position identifiers P_6 and P_8 . Any CF bit or combination of bits can be programmed to read a binary 1 or 0 during any specified number of time frames.
- Control bit assignments, functions, and parameters for time code format E are shown on the following pages.

[Table 5-10](#): IRIG-E control bit assignment for year information.

[Table 5-11](#): Parameters for format E.

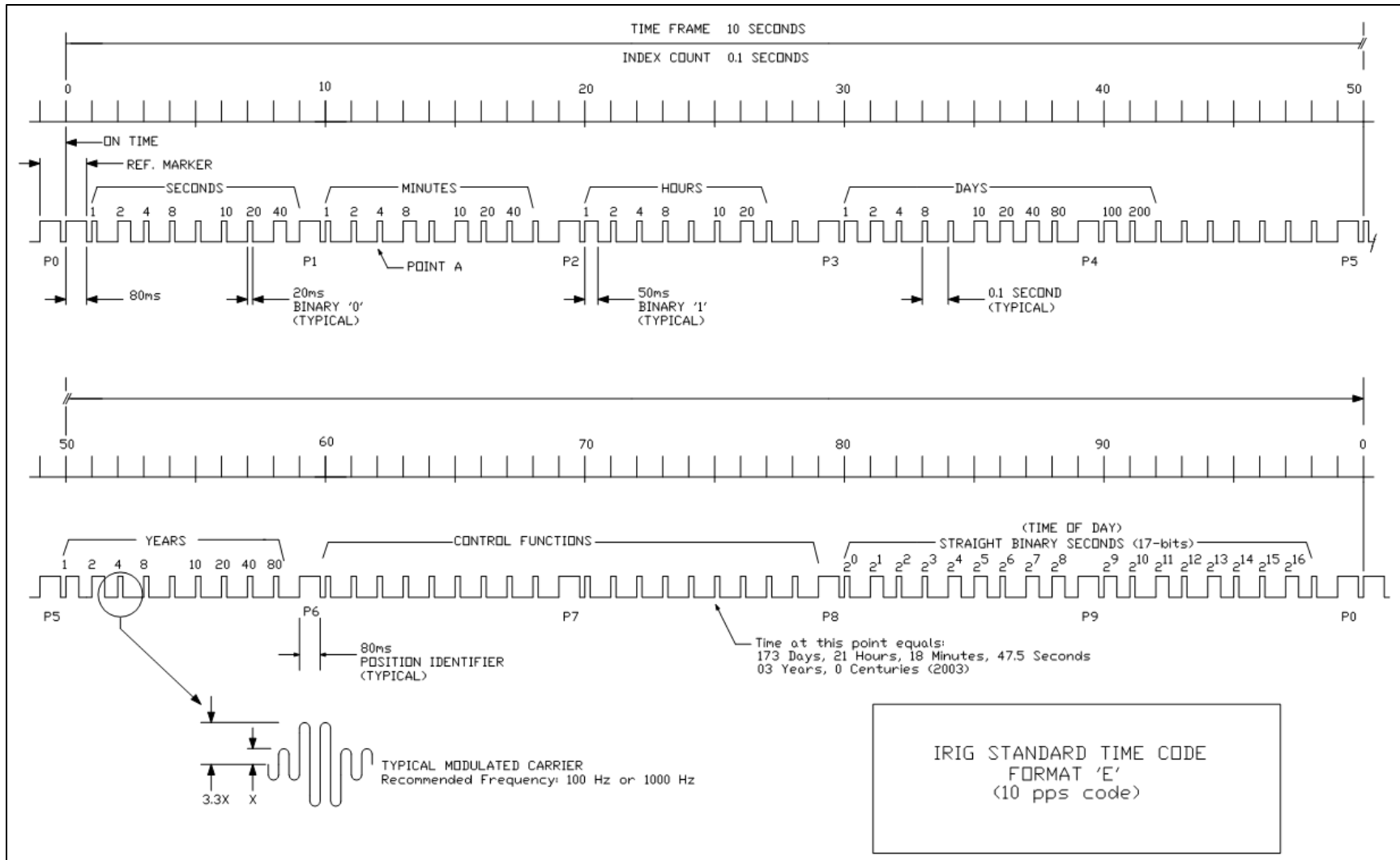

Figure 5-4. Format E: BCD Time-of-Year in Days, Hours, Minutes, Seconds, and Year and Control Bits

Table 5-9. Format E, Signal E001

BCD Time-Of-Year Code (26 Digits)														
Seconds Subword			Minutes Subword			Hours Subword			Days Subword					
BCD Code Digit No.	Subword Digit Wt Seconds	Bit Time ¹	BCD Code Digit No.	Subword Digit Wt Minutes	Bit Time	BCD Code Digit No.	Subword Digit Wt Hours	Bit Time	BCD Code Digit No.	Subword Digit Wt Days	Bit Time	BCD Code Digit No.	Subword Digit Wt Days	Bit Time
Reference Bit		P _r	4	1	P _r + 1.0 sec	11	1	P _r + 2.0 sec	17	1	P _r + 3.0 sec	25	100	P _r + 4.0 sec
Index Marker		P _r + 0.1 sec	5	2	P _r + 1.1 sec	12	2	P _r + 2.1 sec	18	2	P _r + 3.1 sec	26	200	P _r + 4.1 sec
Index Marker		P _r + 0.2 sec	6	4	P _r + 1.2 sec	13	4	P _r + 2.2 sec	19	4	P _r + 3.2 sec	Index Marker		P _r + 4.2 sec
Index Marker		P _r + 0.3 sec	7	8	P _r + 1.3 sec	14	8	P _r + 2.3 sec	20	8	P _r + 3.3 sec	Index Marker		P _r + 4.3 sec
Index Marker		P _r + 0.4 sec	Index Marker		P _r + 1.4 sec	Index Marker		P _r + 2.4 sec	Index Marker		P _r + 3.4 sec	Index Marker		P _r + 4.4 sec
Index Marker		P _r + 0.5 sec	8	10	P _r + 1.5 sec	15	10	P _r + 2.5 sec	21	10	P _r + 3.5 sec	Index Marker		P _r + 4.5 sec
1	10	P _r + 0.6 sec	9	20	P _r + 1.6 sec	16	20	P _r + 2.6 sec	22	20	P _r + 3.6 sec	Index Marker		P _r + 4.6 sec
2	20	P _r + 0.7 sec	10	40	P _r + 1.7 sec	Index Marker		P _r + 2.7 sec	23	40	P _r + 3.7 sec	Index Marker		P _r + 4.7 sec
3	40	P _r + 0.8 sec	Index Marker		P _r + 1.8 sec	Index Marker		P _r + 2.8 sec	24	80	P _r + 3.8 sec	Index Marker		P _r + 4.8 sec
Position Ident. (P ₁)		P _r + 0.9 sec	Position Ident. (P ₂)		P _r + 1.9 sec	Position Ident. (P ₃)		P _r + 2.9 sec	Position Ident. (P ₄)		P _r + 3.9 sec	Position Ident. (P ₅)		P _r + 4.9 sec

Year And Control Functions And SBS (43 Bits)									
Year Function Bit	Bit Time	Control Function Bit	Bit Time	Control Function Bit	Bit Time	Control Function Bit	Bit Time	Control Function Bit	Bit Time
1	P _r + 5.0 sec	1	P _r + 6.0 sec	10	P _r + 7.0 sec	2 ⁰	P _r + 8.0 sec	2 ⁹	P _r + 9.0 sec
2	P _r + 5.1 sec	2	P _r + 6.1 sec	11	P _r + 7.1 sec	2 ¹	P _r + 8.1 sec	2 ¹⁰	P _r + 9.1 sec
4	P _r + 5.2 sec	3	P _r + 6.2 sec	12	P _r + 7.2 sec	2 ²	P _r + 8.2 sec	2 ¹¹	P _r + 9.2 sec
8	P _r + 5.3 sec	4	P _r + 6.3 sec	13	P _r + 7.3 sec	2 ³	P _r + 8.3 sec	2 ¹²	P _r + 9.3 sec
Index Marker	P _r + 5.4 sec	5	P _r + 6.4 sec	14	P _r + 7.4 sec	2 ⁴	P _r + 8.4 sec	2 ¹³	P _r + 9.4 sec
6	P _r + 5.5 sec	6	P _r + 6.5 sec	15	P _r + 7.5 sec	2 ⁵	P _r + 8.5 sec	2 ¹⁴	P _r + 9.5 sec
7	P _r + 5.6 sec	7	P _r + 6.6 sec	16	P _r + 7.6 sec	2 ⁶	P _r + 8.6 sec	2 ¹⁵	P _r + 9.6 sec
8	P _r + 5.7 sec	8	P _r + 6.7 sec	17	P _r + 7.7 sec	2 ⁷	P _r + 8.7 sec	2 ¹⁶	P _r + 9.7 sec
9	P _r + 5.8 sec	9	P _r + 6.8 sec	18	P _r + 7.8 sec	2 ⁸	P _r + 8.8 sec	Index Marker	P _r + 9.8 sec
Position Ident. (P ₆)	P _r + 5.9 sec	Position Ident. (P ₇)	P _r + 6.9 sec	Position Ident. (P ₈)	P _r + 7.9 sec	Position Ident. (P ₉)	P _r + 8.9 sec	Position Ident. (P ₀)	P _r + 9.9 sec

¹The bit time is the time of the bit leading edge and refers to the leading edge of P_r.

Table 5-10. IRIG-E Control Bit Assignment For Year Information			
Pos. ID	Ctrl Bit No.	Designation	Explanation
P ₀ to P ₅ is BCD TOY in seconds, minutes, hours, and days.			
P ₄₉	--	P ₅	Position Identifier #5
P ₅₀	Year 1	Units of Year, BCD 1	LSB 2 digits of year in BCD
P ₅₁	Year 2	Units of Year, BCD 2	IBID
P ₅₂	Year 3	Units of Year, BCD 4	IBID
P ₅₃	Year 4	Units of Year, BCD 8	IBID
P ₅₄	--	Not Used	Index Marker
P ₅₅	Year 5	Tens of Year, BCD 10	MSD 2 digits of year in BCD
P ₅₆	Year 6	Tens of Year, BCD 20	IBID
P ₅₇	Year 7	Tens of Year, BCD 40	IBID
P ₅₈	Year 8	Tens of Year, BCD 80	IBID
P ₅₉	--	P ₆	Position Identifier #6
P ₆₀	1	Not Used	Control Bit
P ₆₁	2	IBID	IBID
P ₆₂	3	IBID	IBID
P ₆₃	4	IBID	IBID
P ₆₄	5	IBID	IBID
P ₆₅	6	IBID	IBID
P ₆₆	7	IBID	IBID
P ₆₇	8	IBID	IBID
P ₆₈	9	IBID	IBID
P ₆₉	--	P ₇	Position Identifier #7
P ₇₀	10	Not Used	Control Bits
P ₇₁	11	IBID	IBID
P ₇₂	12	IBID	IBID
P ₇₃	13	IBID	IBID
P ₇₄	14	IBID	IBID
P ₇₅	15	IBID	IBID
P ₇₆	16	IBID	IBID
P ₇₇	17	IBID	IBID
P ₇₈	18	IBID	IBID
P ₇₉	--	P ₈	Position Identifier #8
P ₆ to P ₈ are control functions.			
P ₈ to P ₀ is the TOD in straight binary seconds.			

Table 5-11. Parameters for Format E	
Pulse Rates	Pulse Duration
Bit rate: 10 pps Position identifier: 1 pps Reference mark: 6 ppm	Index marker: 20 ms Binary 0 or un-encoded bit: 20 ms Binary 1 or coded bit: 50 ms Position identifier: 80 ms Reference bit: 80 ms
Resolution	Mark-To-Space Ratio
0.1 second dc level 10 ms modulated 100 Hz carrier 1 ms modulated 1 kHz carrier	Nominal value of 10:3 Range of 3:1 to 6:1

5.6 Format G

The following is a detailed description of IRIG time code format G.

- The beginning of each 0.01-second time frame is identified by two consecutive 80- μ s bits, P_0 and P_r . The leading edge of P_r is the on-time reference point for the succeeding time code word. Position identifiers P_0 and P_1 through P_9 each use 0.1 ms of the time frame, one full index count duration. Position identifiers occur every 0.1 ms before the leading edge of each succeeding tenth index count (see [Figure 5-5](#)).
- The time code words and the CFs presented during the time frame are pulse-width coded. The time code bit rate is 10 kpps. The time code reference bit's leading edge is the on-time reference point for all bits and is the index count reference point. The binary 0 and index markers have durations of 20 μ s and the binary 1 has duration of 50 μ s.
- The BCD TOY code word consists of 38 bits beginning at index count 1. The subword bits occur between position identifiers P_0 and P_6 : 7 for seconds, 7 for minutes, 6 for hours, 10 for days, 4 for tenths of seconds, and 4 for hundredths of seconds. There are 8 bits for year information occurring between position identifiers P_6 and P_7 to complete the BCD time code word. An index marker occurs between the decimal digits in each subword, except for fractional seconds, to provide visual separation. The LSB occurs first, except for the fractional second information that follows the day-of-year information. The code recycles yearly. Each bit position is identified in [Table 5-12](#).
- There are 27 control bits occurring between position identifiers P_7 and P_0 . Any CF bit or combination of bits can be programmed to read a binary 1 or 0 during any specified number of time frames. Each control bit position is identified in [Table 5-12](#).
- Control bit assignments, functions, and parameters for time code format G are shown on the following pages.

[Table 5-13](#): IRIG-G control bit assignment for year information.

[Table 5-14](#): Parameters for format G.

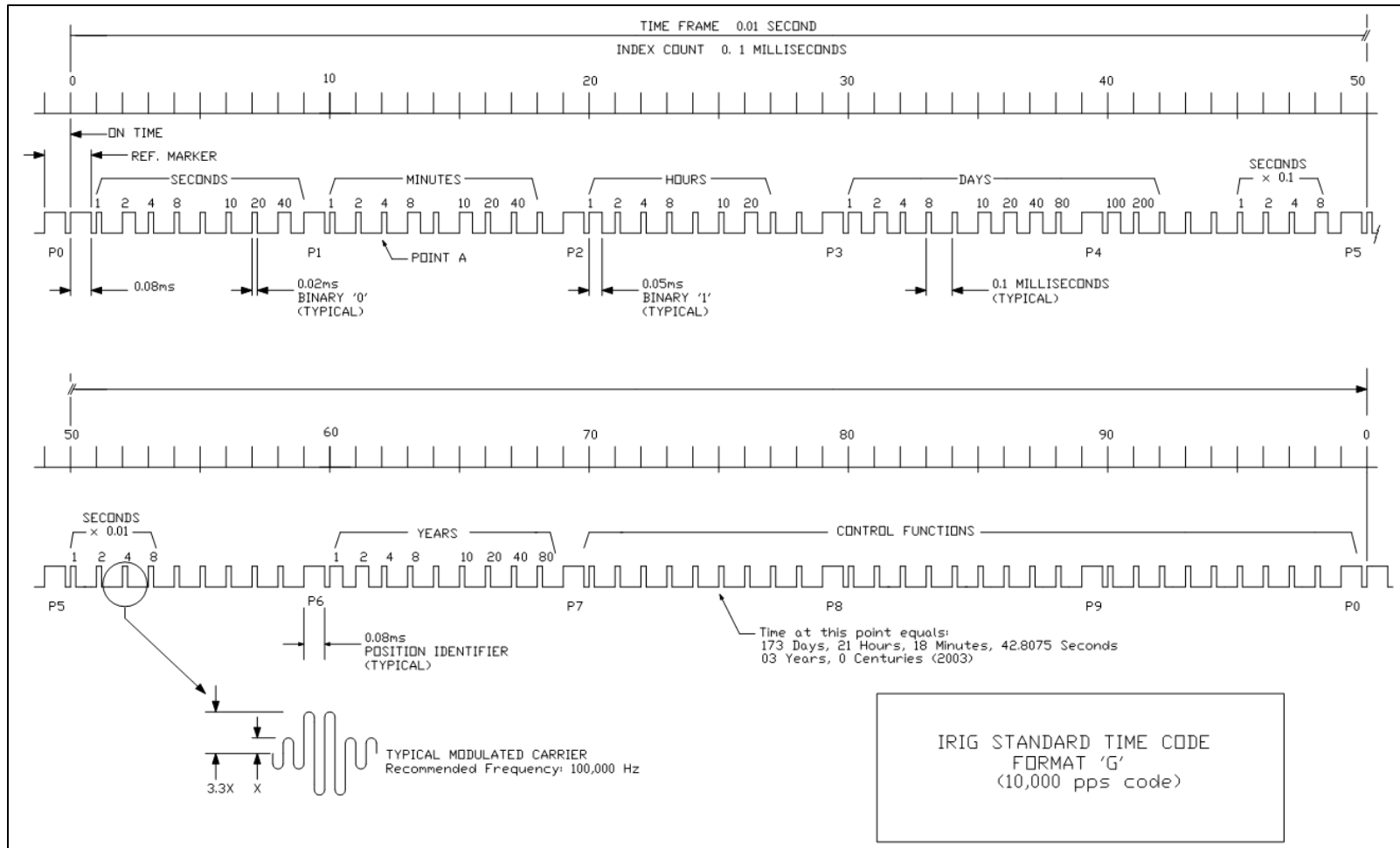

Figure 5-5. Format G: BCD Time-of-Year in Days, Hours, Minutes, Seconds, and Year and Fractions-of-Seconds, and Control Bits

Table 5-12. Format G, Signal G001

BCD Time-of-Year Code (38 Digits)								
Seconds Subword			Minutes Subword			Hours Subword		
BCD Code Digit No.	Subword Digit Wt Seconds	Bit Time ¹	BCD Code Digit No.	Subword Digit Wt Minutes	Bit Time	BCD Code Digit No.	Subword Digit Wt Hours	Bit Time
Reference Bit		P _r	8	1	P _r + 1.0 ms	15	1	P _r + 2.0 ms
1	1	P _r + 0.1 ms	9	2	P _r + 1.1 ms	16	2	P _r + 2.1 ms
2	2	P _r + 0.2 ms	10	4	P _r + 1.2 ms	17	4	P _r + 2.2 ms
3	4	P _r + 0.3 ms	11	8	P _r + 1.3 ms	18	8	P _r + 2.3 ms
4	8	P _r + 0.4 ms	Index Bit		P _r + 1.4 ms	Index Bit		P _r + 2.4 ms
Index Bit		P _r + 0.5 ms	12	10	P _r + 1.5 ms	19	10	P _r + 2.5 ms
5	10	P _r + 0.6 ms	13	20	P _r + 1.6 ms	20	20	P _r + 2.6 ms
6	20	P _r + 0.7 ms	14	40	P _r + 1.7 ms	Index Bit		P _r + 2.7 ms
7	40	P _r + 0.8 ms	Index Bit		P _r + 1.8 ms	Index Bit		P _r + 2.8 ms
Position Ident. (P ₁)		P _r + 0.9 ms	Position Ident. (P ₂)		P _r + 1.9 ms	Position Ident. (P ₃)		P _r + 2.9 ms
Days And Fractional Second Subword					Fractional Second Subword			
BCD Code Digit No.	Subword Digit Wt Days	Bit Time	BCD Code Digit No.	Subword Digit Wt Days	Bit Time	BCD Code Digit No.	Subword Digit Wt Seconds	Bit Time
21	1	P _r + 3.0 ms	29	100	P _r + 4.0 ms	35	0.01	P _r + 5.0 ms
22	2	P _r + 3.1 ms	30	200	P _r + 4.1 ms	36	0.02	P _r + 5.1 ms
23	4	P _r + 3.2 ms	Index Bit		P _r + 4.2 ms	37	0.04	P _r + 5.2 ms
24	8	P _r + 3.3 ms	Index Bit		P _r + 4.3 ms	38	0.08	P _r + 5.3 ms
Index Bit		P _r + 3.4 ms	Index Bit		P _r + 4.4 ms	Index Bit		P _r + 5.4 ms
25	10	P _r + 3.5 ms	31	0.1	P _r + 4.5 ms	Index Bit		P _r + 5.5 ms
26	20	P _r + 3.6 ms	32	0.2	P _r + 4.6 ms	Index Bit		P _r + 5.6 ms
27	40	P _r + 3.7 ms	33	0.4	P _r + 4.7 ms	Index Bit		P _r + 5.7 ms
28	80	P _r + 3.8 ms	34	0.8	P _r + 4.8 ms	Index Bit		P _r + 5.8 ms
Position Ident. (P ₄)		P _r + 3.9 ms	Position Ident. (P ₅)		P _r + 4.9 ms	Position Ident. (P ₆)		P _r + 5.9 ms
Year and Control Functions (36 Bits)								
Year Function Bit	Bit Time	Control Function Bit	Bit Time	Control Function Bit	Bit Time	Control Function Bit	Bit Time	
1	P _r + 6.0 ms Units of Year 01	1	P _r + 7.0 ms	10	P _r + 8.0 ms	19	P _r + 9.0 ms	
2	Units of Year 02	2	P _r + 7.1 ms	11	P _r + 8.1 ms	20	P _r + 9.1 ms	
3	Units of Year 04	3	P _r + 7.2 ms	12	P _r + 8.2 ms	21	P _r + 9.2 ms	
4	Units of Year 08	4	P _r + 7.3 ms	13	P _r + 8.3 ms	22	P _r + 9.3 ms	
Index Mark	P _r + 6.4 ms	5	P _r + 7.4 ms	14	P _r + 8.4 ms	23	P _r + 9.4 ms	
6	Tens of Year 10	6	P _r + 7.5 ms	15	P _r + 8.5 ms	24	P _r + 9.5 ms	
7	Tens of Year 20	7	P _r + 7.6 ms	16	P _r + 8.6 ms	25	P _r + 9.6 ms	
8	Tens of Year 40	8	P _r + 7.7 ms	17	P _r + 8.7 ms	26	P _r + 9.7 ms	
9	Tens of Year 80	9	P _r + 7.8 ms	18	P _r + 8.8 ms	27	P _r + 9.8 ms	
Position Ident. (P ₇)	P _r + 6.9 ms	Position Ident. (P ₈)	P _r + 7.9 ms	Position Ident. (P ₉)	P _r + 8.9 ms	Position Ident. (P ₀)	P _r + 9.9 ms	

¹The bit time is the time of the bit leading edge and refers to the leading edge of P_r.

Table 5-13. IRIG-G Control Bit Assignment for Year Information			
Pos. ID	Ctrl Bit No	Designation	Explanation
P ₀ to P ₆ is BCD TOY in seconds, minutes, hours, days, and fraction of seconds.			
P ₅₉	-	P ₆	Position Identifier #6
P ₆₀	Year 1	Units Year, BCD 1	LSB 2 digits of year in BCD
P ₆₁	Year 2	Units Year, BCD 2	IBID
P ₆₂	Year 3	Units Year, BCD 4	IBID
P ₆₃	Year4	Units Year, BCD 8	IBID
P ₆₄	Index Marker	Units Not Used	Unassigned
P ₆₅	Year 5	Units Year, BCD 10	MSB 2 digits of year in BCD
P ₆₆	Year 6	Units Year, BCD 20	IBID
P ₆₇	Year 7	Units Year, BCD 40	IBID
P ₆₈	Year 8	Units Year, BCD 80	IBID
P ₆₉	--	P ₇	Position Identifier #7
P ₇₀	1	Not Used	Control Bit
P ₇₁	2	IBID	IBID
P ₇₂	3	IBID	IBID
P ₇₃	4	IBID	IBID
P ₇₄	5	IBID	IBID
P ₇₅	6	IBID	IBID
P ₇₆	7	IBID	IBID
P ₇₇	8	IBID	IBID
P ₇₈	9	IBID	IBID
P ₇₉	--	P ₈	Position Identifier #8
P ₈₀	10	Not Used	Control Bit
P ₈₁	11	IBID	IBID
P ₈₂	12	IBID	IBID
P ₈₃	13	IBID	IBID
P ₈₄	14	IBID	IBID
P ₈₅	15	IBID	IBID
P ₈₆	16	IBID	IBID
P ₈₇	17	IBID	IBID
P ₈₈	18	IBID	IBID
P ₈₉	--	P ₉	Position Identifier #9
P ₉₀	19	Not Used	Control Bit
P ₉₁	20	IBID	IBID
P ₉₂	21	IBID	IBID
P ₉₃	22	IBID	IBID
P ₉₄	23	IBID	IBID
P ₉₅	24	IBID	IBID
P ₉₆	25	IBID	IBID
P ₉₇	26	IBID	IBID
P ₉₈	27	IBID	IBID
P ₉₉	--	P ₁₀	Position Identifier #10

P_8 to P_0 are control functions.

Note: The bit time is the time of the bit leading edge and refers to the leading edge of P_r

Table 5-14. Parameters For Format G	
Pulse Rates	Pulse Duration
Bit rate: 10 kpps Position identifier: 1 kpps Reference marker: 100 pps	Index marker: 20 μ s Binary 0 or un-encoded bit: 20 μ s Binary 1 or coded bit: 50 μ s Position identifiers: 80 μ s Reference bit: 80 μ s
Resolution	Mark-To-Space Ratio
0.1 ms dc level 10 μ s modulated 100 kHz carrier	Nominal value of 10:3 Range of 3:1 to 6:1

5.7 Format H

The following is a detailed description of IRIG time code format H.

- The beginning of each 1-minute time frame is identified by two consecutive 0.8-second bits, P_0 and P_r . The leading edge of P_r is the on-time reference point for the succeeding time code words. Position identifiers P_0 and P_1 through P_5 each use 1 second of the time frame, one full index count duration. Position identifiers occur every 1 second before the leading edge of each succeeding tenth index count (see [Figure 5-6](#)).
- The time code word and the CFs presented during the time frame are pulse-width coded. The binary 0 and the index markers each have duration of 0.2 seconds and a binary 1 has duration of 0.5 seconds. The leading edge is the 1-pps on-time reference point for all bits.
- The BCD TOY consists of 23 bits beginning at index count 10. The subword bits occur between position identifiers P_1 and P_5 : 7 for minutes, 6 for hours, and 10 for days to complete the time code word. An index marker occurs between the decimal digits in each subword to provide separation for visual resolution. The LSB occurs first. The code recycles yearly. Each bit position is identified in [Table 5-15](#).
- There are 9 CFs occurring between position identifiers P_5 and P_0 . Any CF bit or combination of bits can be programmed to read a binary 1 or 0 during any specified number of time frames.
- Details of the IRIG format H parameters are shown at [Table 5-16](#).

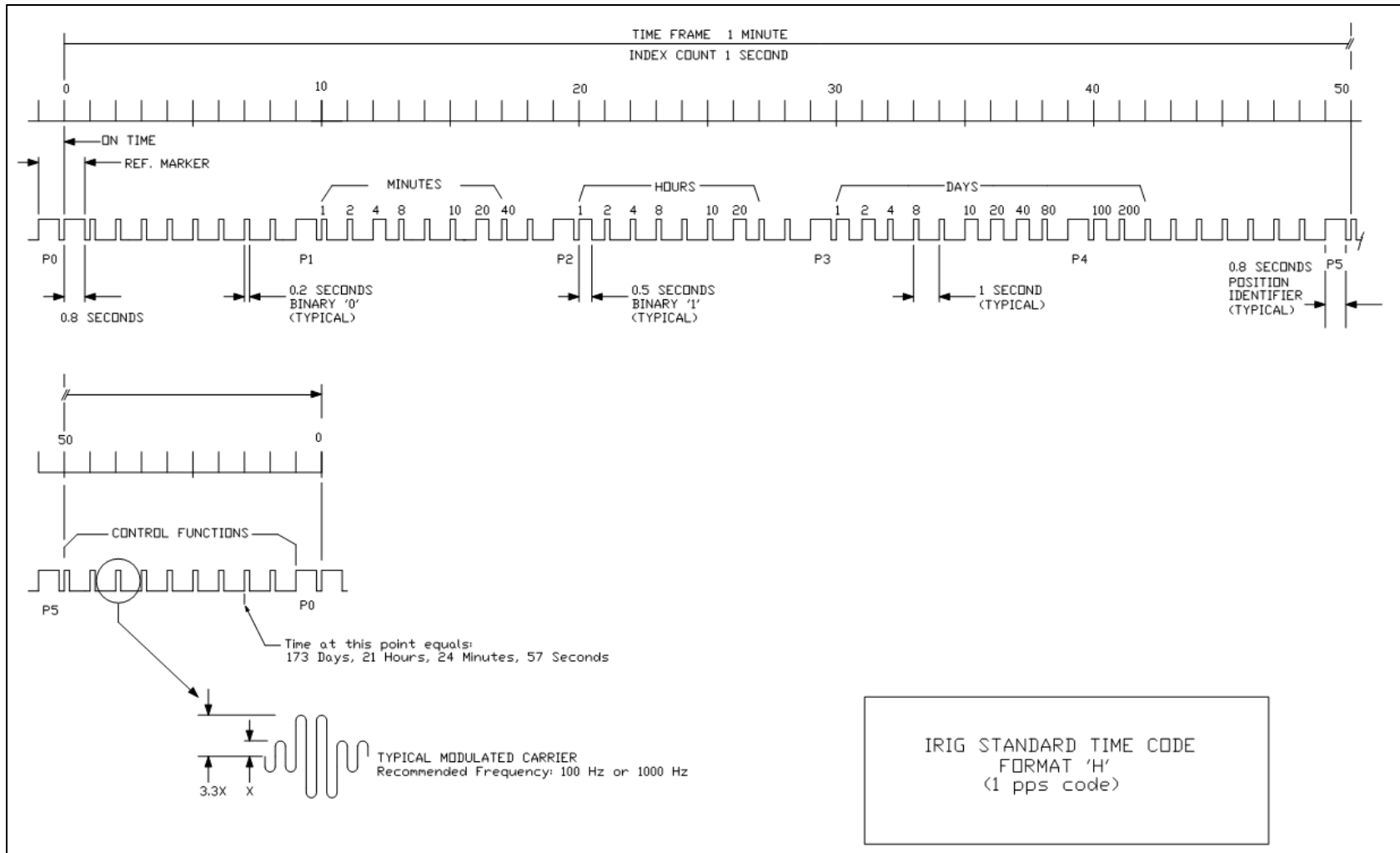

Figure 5-6. Format H: BCD Time-of-Year in Days, Hours, Minutes, and Control Bits

Table 5-15. Format H, Signal H001

BCD Time-of-Year Code (23 Digits)								
Seconds Subword			Minutes Subword			Hours Subword		
BCD Code Digit No.	Subword Digit Wt Seconds	Bit Time ¹	BCD Code Digit No.	Subword Digit Wt Minutes	Bit Time	BCD Code Digit No.	Subword Digit Wt Hours	Bit Time
	Reference Bit	P _r	1	1	P _r + 10 sec	8	1	P _r + 20 sec
	Index Marker	P _r + 1 sec	2	2	P _r + 11 sec	9	2	P _r + 21 sec
	Index Marker	P _r + 2 sec	3	4	P _r + 12 sec	10	4	P _r + 22 sec
	Index Marker	P _r + 3 sec	4	8	P _r + 13 sec	11	8	P _r + 23 sec
	Index Marker	P _r + 4 sec	Index Marker		P _r + 14 sec	Index Marker		P _r + 24 sec
	Index Marker	P _r + 5 sec	5	10	P _r + 15 sec	12	10	P _r + 25 sec
	Index Marker	P _r + 6 sec	6	20	P _r + 16 sec	13	20	P _r + 26 sec
	Index Marker	P _r + 7 sec	7	40	P _r + 17 sec	Index Marker		P _r + 27 sec
	Index Marker	P _r + 8 sec	Index Marker		P _r + 18 sec	Index Marker		P _r + 28 sec
	Position Ident. (P ₁)	P _r + 9 sec	Position Ident. (P ₂)		P _r + 19 sec	Position Ident. (P ₃)		P _r + 29 sec
Days Subword					Control Functions (9 Bits)			
BCD Code Digit No.	Subword Digit Wt Days	Bit Time	BCD Code Digit No.	Subword Digit Wt Days	Bit Time	Control Function Bit		Bit Time
14	1	P _r + 30 sec	22	100	P _r + 40 sec	1		P _r + 50 sec
15	2	P _r + 31 sec	33	200	P _r + 41 sec	2		P _r + 51 sec
16	4	P _r + 32 sec	Index Marker		P _r + 42 sec	3		P _r + 52 sec
17	8	P _r + 33 sec	Index Marker		P _r + 43 sec	4		P _r + 53 sec
Index Marker		P _r + 34 sec	Index Marker		P _r + 44 sec	5		P _r + 54 sec
18	10	P _r + 35 sec	Index Marker		P _r + 45 sec	6		P _r + 55 sec
19	20	P _r + 36 sec	Index Marker		P _r + 46 sec	7		P _r + 56 sec
20	40	P _r + 37 sec	Index Marker		P _r + 47 sec	8		P _r + 57 sec
21	80	P _r + 38 sec	Index Marker		P _r + 48 sec	9		P _r + 58 sec
Position Ident. (P ₄)		P _r + 39 sec	Position Ident. (P ₅)		P _r + 49 sec	Position Ident. (P ₀)		P _r + 59 sec

¹The bit time is the time of the bit leading edge and refers to the leading edge of P_r.

Table 5-16. Parameters for Format H	
Pulse Rates	Pulse Duration
Bit rate: 1 pps Position identifier: 6 ppm Reference marker: 1 ppm	Index marker: 0.2 s Binary 0 or un-encoded bit: 0.2 s Binary 1 or coded bit: 0.5 s Position identifiers: 0.8 s Reference bit: 0.8 s
Resolution	Mark-To-Space Ratio
1 second dc level 10 ms modulated 100 Hz carrier 1 ms modulated 1 kHz carrier	Nominal value of 10:3 Range of 3:1 to 6:1

This page intentionally left blank.

Appendix A

Leap Year/Leap Second Conventions

A.1 Leap Year Convention

The USNO Astronomical Applications Department defines the leap year according to the Gregorian calendar, which was instituted by Pope Gregory VIII in 1582 to keep the year in a cycle with the seasons. The average Gregorian calendar year, technically known as the Tropical Year, is approximately 365.2425 days in length and it will take about 3,326 years before the Gregorian calendar is as much as one day out of step with the seasons.

According to the Gregorian calendar, which is the civil calendar in use today, years that are evenly divisible by 4 are leap years with the exception of century years that are not evenly divisible by 400. This means that years 1700, 1800, 1900, 2100, 2200, and 2500 are NOT leap years and that years 1600, 2000, and 2400 ARE leap years.

Additional information can be found at the following USNO web sites.

- <http://timeanddate.com/date/leapyear.html>
- http://aa.usno.navy.mil/faq/docs/leap_years.html

A.2 Leap Second Convention

Civil time is occasionally adjusted by one-second increments to insure that the difference between a uniform time-scale defined by International Atomic Time (TAI) does not differ from the Earth's rotational time by more than 0.9 seconds. Consequently, UTC, also an atomic time, was established in 1972 and is adjusted for the Earth's rotation and forms the basis for civil time.

There have been 35 leap seconds added to UTC to keep it in synchronization with the rotation of the earth. In 1980, when the Global Positioning System (GPS) came into being, it was initially synchronized to UTC; however, GPS time does not add or subtract leap seconds, and as of this writing, GPS time is 16 seconds ahead of UTC. The relationship between TAI and UTC is given by a simple accumulation of leap seconds occurring approximately once per year. If required, time changes are made on December 31 and on June 30 at 2400 hours.

At any instant (i), $T_i = \text{TAI time}$,
 $U_i = \text{UTC time expressed in seconds, and}$
 $T_i = U_i + L_i$

where L_i is the accumulated leap second additions between the epoch and the instant (i).

The USNO maintains a history of accumulated leap seconds on one of their web sites. The site URL is: <ftp://maia.usno.navy.mil/ser7/tai-utc.dat>, which provides a list of TAI minus UTC from 1961 to 1999. As of the publication date of this document, the last leap second occurred in June 2012. Additional information can be obtained from the USNO's Earth Orientation Department at the following web sites.

- <http://maia.usno.navy.mil/eo/leapsec.html>
- <http://tycho.usno.navy.mil/leapsec.990505.html>

This page intentionally left blank.

Appendix B

BCD Count/Binary Count

Refer to [Table B-1](#) for the BCD count data and [Table B-2](#) for binary count data.

Table B-1. BCD Count (8n 4n 2n 1n)		
Decimal Number	n	BCD Bits
1	1	1
5	1	3
10	10	5
15	10	5
150	100	9
1500	1x10 ³	13
15,000	10x10 ³	17
150,000	100x10 ³	21
1,500,000	1x10 ⁶	25
15,000,000	10x10 ⁶	29
150,000,000	100x10 ⁶	33
1,500,000,000	1x10 ⁹	37
15,000,000,000	10x10 ⁹	41
150,000,000,000	100x10 ⁹	45
1,500,000,000,000	1x10 ¹²	49
15,000,000,000,000	10x10 ¹²	53
150,000,000,000,000	100x10 ¹²	57

Table B-2. Binary Count (2n)			
Decimal Number	Binary Number	Decimal Number	Binary Number
N	2 ⁿ	n	2 ⁿ
0	1		
1	2	26	67,108,864
2	4	27	134,217,728
3	8	28	268,435,456
4	16	29	536,870,912
5	32	30	1,073,741,824
6	64	31	2,147,483,648
7	128	32	4,294,967,296
8	256	33	8,589,934,592
9	512	34	17,179,869,184
10	1024	35	34,359,738,368
11	2048	36	68,719,476,736
12	4096	37	137,438,953,472
13	8192	38	274,877,906,944
14	16,384	39	549,755,813,888

Table B-2. Binary Count (2n)			
Decimal Number	Binary Number	Decimal Number	Binary Number
15	32,768	40	1,099,511,627,776
16	65,536	41	2,199,023,255,552
17	131,072	42	4,398,046,511,104
18	262,144	43	8,796,093,022,208
19	524,288	44	17,592,186,044,416
20	1,048,576	45	35,184,372,088,832
21	2,097,152	46	70,368,744,177,664
22	4,194,304	47	140,737,488,355,328
23	8,388,608	48	281,474,976,710,656
24	16,777,216	49	562,949,953,421,312
25	33,554,432	50	1,125,899,906,842,620

Appendix C

Hardware Design Considerations

Table C-1. Time Code Generator Hardware Minimum Design Considerations			
Code	Level (dc) Pulse Rise Time Between the 10 and 90% Amplitude Points	Jitter Modulated at Carrier Frequency	Jitter Level (dc) Pulse-to-Pulse
Format A	≤ 200 ns	$\leq 1\%$	≤ 100 ns
Format B	≤ 1 μ s	$\leq 1\%$	≤ 200 ns
Format D	≤ 1 μ s	$\leq 1\%$	≤ 200 ns
Format E	≤ 1 μ s	$\leq 1\%$	≤ 200 ns
Format G	≤ 20 ns	$\leq 1\%$	≤ 20 ns
Format H	≤ 1 μ s	$\leq 1\%$	≤ 200 ns

This page intentionally left blank

Appendix D

Glossary

D.1 Definitions of Terms And Usage

Accuracy - Systematic uncertainty (deviation) of a measured value with respect to a standard reference.

Binary Coded Decimal (BCD) - A numbering system that uses decimal digits encoded in a binary representation ($1n\ 2n\ 4n\ 8n$) where $n=1, 10, 100, 1\ k, 10\ k\dots N$ (see appendix B).

Binary numbering system (Straight Binary) - A numbering system that has two as its base and uses two symbols, usually denoted by 0 and 1 (see appendix B).

Frame rate - The repetition rate of the time code.

Global Positioning System (GPS) - a U.S. owned utility that provides users with positioning, navigation, and timing services.

IBID - Latin, short for ibidem, meaning “in the same place.”

Index count - The number that identifies a specific bit position with respect to a reference marker.

Index markers - Uuencoded, periodic, interpolating bits in the time code.

Instrumentation Timing - A parameter serving as the fundamental variable in terms of which data may be correlated.

Leap second - See appendix A.

Leap year - See appendix A.

On-time - The state of any bit being coincident with a standard time reference (USNO or National Bureau of Standards or other national laboratory).

On-time reference marker - The leading edge of the reference bit P_r of each time frame.

Position identifier - A particular bit denoting the position of a portion or all of a time code.

Precision - An agreement of measurement with respect to a defined value.

Reference marker - A periodic combination of bits that establishes that instant of time defined by the time code word.

Resolution (of a time code) - The smallest increment of time or least significant bit that can be defined by a time code word or subword.

Second - Basic unit of time or time interval in the International System of Units (SI).

Subword - A subdivision of the time code word containing only one type of time unit, for example, days, hours, seconds, or milliseconds.

Time - Signifies epoch, i.e., the designation of an instant of time on a selected time scale such as astronomical, atomic, or UTC.

Time code - A system of symbols used for identifying specific instants of time.

Time code word - A specific set of time code symbols that identifies one instant of time. A time code word may be subdivided into subwords.

Time frame - The time interval between consecutive reference markers that contains all the bits that determine the time code format.

Time interval - The duration between two instants read on the same time scale, usually expressed in seconds or in a multiple or sub multiple of a second.

Time reference - The basic repetition rate chosen as the common time reference for all instrumentation timing (usually 1 pps).

Time T_0 - The initial time $0^h 0^m 0^s$, January 1, or the beginning of an epoch.

Appendix E

Citations

Range Commanders Council. IRIG Standard Parallel Binary and Parallel Binary Coded Decimal Time Code Formats. RCC 205-87. August 1987. May be superseded by update. Retrieved on 29 July 2015. Available to RCC members with Private Page access at [https://wadmext.wsmr.army.mil/site/rccpri/Publications/205-87 IRIG Standard Parallel Binary and Parallel Binary Coded Decimal Time Code Formats/](https://wadmext.wsmr.army.mil/site/rccpri/Publications/205-87_IRIG_Standard_Parallel_Binary_and_Parallel_Binary_Coded_Decimal_Time_Code_Formats/).

*** * * END OF DOCUMENT * * ***