

Model 935A Current Source Operation Manual

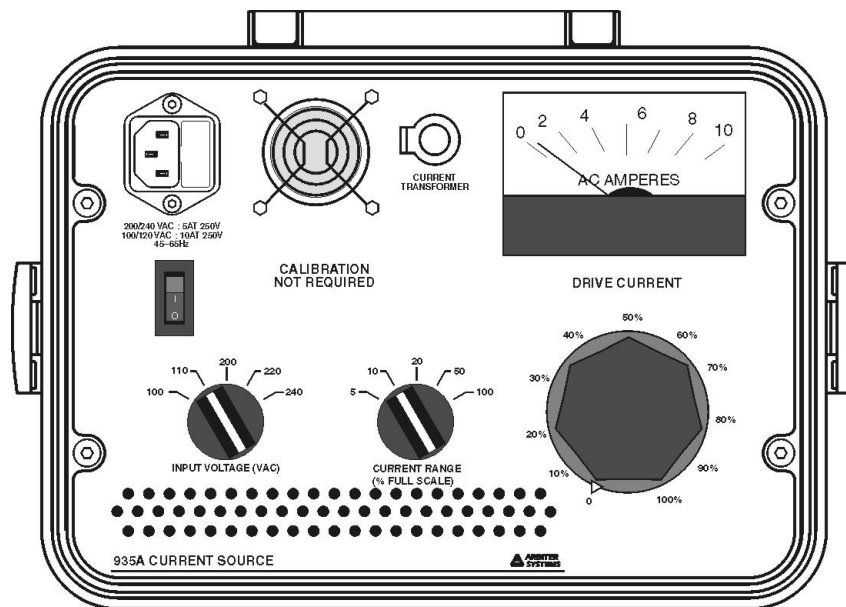

Arbiter Systems, Inc.
Paso Robles, CA 93446
U.S.A.

Description

This manual is issued for reference only, at the convenience of Arbiter Systems. Reasonable effort was made to verify that all contents were accurate as of the time of publication. Check with Arbiter Systems at the address below for any revisions made since the original date of publication.

Contact Information

Arbiter Systems, Inc.
1324 Vendels Circle, Suite 121
Paso Robles, CA 93446
USA
(805) 237-3831
Website: www.arbiter.com
<mailto:techsupport@arbiter.com>
<mailto:sales@arbiter.com>

What This Manual Covers

This manual describes the set up and operation of the Model 935A Current Source.

LIMITED WARRANTY

Arbiter Systems makes no warranty, expressed or implied, on any product manufactured or sold by Arbiter Systems except for the following limited warranty against defects in materials and workmanship on products manufactured by Arbiter Systems.

Clock products manufactured by Arbiter Systems are guaranteed against defective materials and workmanship under normal use and service from the date of delivery for the period of one year. The responsibility of Arbiter Systems under this warranty is limited to repair or replacement, at Arbiter Systems' option, of any product found to be defective. Arbiter Systems shall have no liability under this warranty unless it receives written notice of any claimed defect.

For warranty service or repair, products must be returned to a service facility designated by Arbiter Systems. Buyer shall prepay all shipping charges to Arbiter Systems, and Arbiter Systems shall pay shipping charges incurred in returning the product to Buyer. However, Buyer shall pay all shipping charges, duties and taxes for products returned to Buyer in a country other than the United States of America.

THE WARRANTY SET FORTH HEREIN CONSTITUTES THE ONLY WARRANTY OBLIGATIONS OF ARBITER SYSTEMS, EXPRESSED OR IMPLIED, STATUTORY, BY OPERATION OF LAW, OR OTHERWISE. ARBITER SYSTEMS DISCLAIMS ANY WARRANTY OF MERCHANTABILITY OR FITNESS FOR A PARTICULAR PURPOSE, AND BUYER EXPRESSLY WAIVES ALL OTHER WARRANTIES.

This limited warranty does not extend to any product, which has been subject to

1. Improper use or application, abuse, or operation beyond its rated capacity, or contrary to the instructions in the operation and maintenance manuals (if any);
2. Accident;
3. Repair or maintenance performed by Buyer, except in accordance with the operation and maintenance manuals, if any, and any special instructions of Arbiter Systems;
4. Modification without the prior written authorization of Arbiter Systems (whether by the substitution of non-approved parts or otherwise). The remedies provided herein are Buyer's sole and exclusive remedies. In no event shall Arbiter Systems be liable for direct, indirect, incidental or consequential damages (including loss of profits), whether based on contract, tort, or other legal theory.

FOR THE FASTEST POSSIBLE SERVICE, PLEASE PROCEED AS FOLLOWS:

1. Notify Arbiter Systems, Inc., specifying the instrument model number and serial number and giving full details of the difficulty. Service data or instrument-return authorization will be provided upon receipt of this information.
2. If instrument return is authorized, forward prepaid to the manufacturer. If it is determined that the instrument is not covered by this warranty, an estimate will be made before the repair work begins, if requested.

See Contact Information on page ii.

Model 935A

Current Source

Operation Manual

Chapter 1	Product Description
Chapter 2	Specifications
Chapter 3	Recommended Usage

Copyright Arbiter Systems Incorporated May 2008. All rights reserved. International copyright secured.

PD0041000A

Contents

- 1 Product Description** **1**
 - 1.1 Introduction 1

- 2 Specifications** **3**
 - 2.1 I/O Configuration 3
 - 2.1.1 Input 3
 - 2.1.2 Output 3
 - 2.2 General 3
 - 2.2.1 Physical 3
 - 2.2.2 Environmental 4
 - 2.3 Controls 4
 - 2.3.1 Input 4
 - 2.3.2 Output 4

- 3 Recommended Usage** **5**
 - 3.1 Operation 5
 - 3.1.1 Suggested Setup 5
 - 3.1.2 935A Setup 6
 - 3.1.3 Calculating Burden 6
 - 3.1.4 Other Burden Calculations 7
 - 3.1.5 Burden in Practice 8
 - 3.1.6 Setup Example 8
 - 3.1.7 Calibrating Instrument Current Transformers 9

Chapter 1

Product Description



1.1 Introduction

This manual covers the specifications and use of the Model 935A Current Source. The Model 935A is designed to drive high currents, up to 1000 amps rms, through low impedance loads. Output current is produced at the input line frequency through a toroidal current transformer. The input line level is selectable from 100, 120, 200, 220, and 240 volts rms. An output range selector switch and variable transformer allow easy setting of the output current within the attainable range.

The Model 935A is an ideal source for testing instrument current transformers. Use the Model 935A Current Source in conjunction with the Model 931A Power System Analyzer and the Model 936A Reference Current Transformer to accurately measure the ratio and phase angle errors on a wide variety of current transformers.

Chapter 2

Specifications

The Model 935A is designed to operate from various line voltages with line frequencies from 45 to 65 Hz. It includes an external current transformer (CT) that connects to the front of the Model 935A. Input power is selectable through the rotary switch on the front panel. Primary output current is controlled through a range switch and dial to cover the target current. Finally, you can view the primary current on a standard AC Ammeter conveniently located on the upper right of the front panel.

2.1 I/O Configuration

2.1.1 Input

Line	100, 120, 200, 220, 240
Frequency	45 – 65 Hz
Inlet	IEC-320 with fuse and mating cordset. Specify option P01-P10

2.1.2 Output

Current	1000+ Amps
Power	840 Watts rms, maximum

2.2 General

2.2.1 Physical

Case Size	205 x 305 x 225 mm (8 x 12 x 8.75 in.)
Weight	16 kg (35 lbs) maximum
CurrentTransformer	90 mm (3.5 in) ID Nominal, 3 m (8 ft) cable length

2.2.2 Environmental

Temperature	Operating: 0°C to +40°C, Nonoperating: -40°C to +85°C
Humidity	Noncondensing

2.3 Controls

2.3.1 Input

Control	5-position rotary switch
---------	--------------------------

2.3.2 Output

Control	5-position rotary switch, percent full scale Large dial (rheostat), 0 to 100 percent
---------	---

Chapter 3

Recommended Usage

3.1 Operation

Operating the Model 935A is very simple, but designed to operate most efficiently through low impedance loads (or burden) – on the order of a tenth (1/10) to a thousandth (1/1000) of an ohm. If not connected to a very low burden, the Model 935A will not drive rated currents through the secondary winding of the external current transformer. To achieve the best results, make sure that the burden on the 935A is as low as you can make it. Use very short cables of large gauge (or cross section) with solid connections.

3.1.1 Suggested Setup

Figure 3.1 illustrates a simple method to accurately verify currents through a common electrical loop. The loop is energized by the Source CT and detected by the Reference CT. The loop itself is made up of 3.04 meters (10 feet) of # 0000 welding cable and connected by large ring terminals with two bolts.

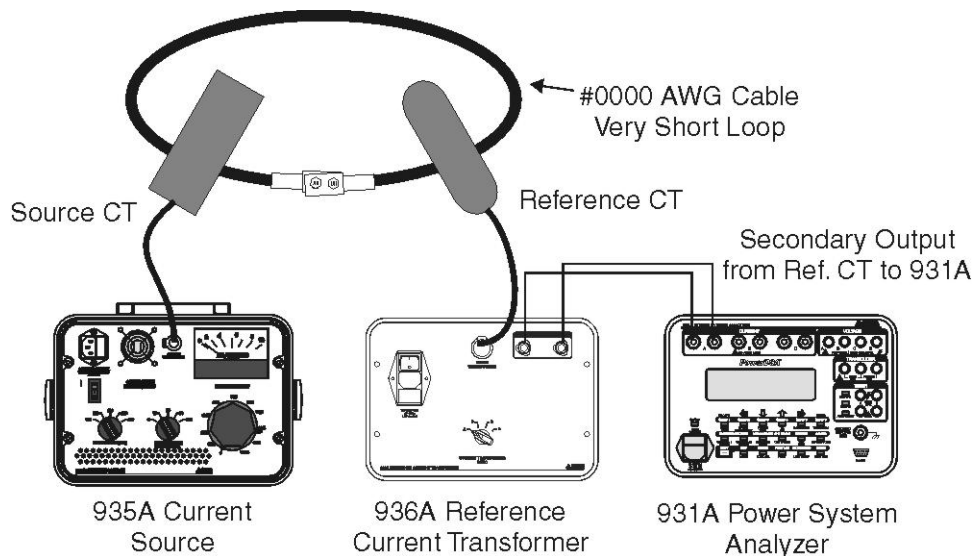

Figure 3.1: Model 935A Test Setup

3.1.2 935A Setup

Listed below are steps that you would normally take to set up the Model 935A for energizing a circuit.

1. Connect the overall test system as in Figure 3.1, or similar. Note: It is essential to have a complete loop as illustrated. If you want to test the Model 935A by itself, you must have a connected loop.
2. To measure the output current using the Model 936A Reference CT, make sure that the Reference CT is included in the loop.
3. Connect cables from the Model 936A Current Output connectors to one of the Model 931A Current channels (A, B, or C). You may use any other meter rated for the output current.
4. Press the **SHIFT** > **SCALE** keys on the 931A to set the scaling according to that set on the Model 936A Reference CT. For example, if you choose the Current Ratio of 1000:5 on the 936A, then you would set the scale ratio for Ia, Ib, or Ic to 200 (1000 ÷ 5).
5. Connect the power cord to the Model 935A.
6. Connect the current transformer cable to the Model 935A Current Transformer connector.
7. Set the Input Voltage (VAC) switch to local voltage; 100, 120, 200, 220, or 240 VAC.
8. Set the Current Range switch (% Full Scale) to 5, 10, 20, 50, 100 percent.
9. Set the Drive Current dial to 0%.
10. Press the power switch to "ON".
11. Gradually, rotate the Drive Current clockwise to the required amount. You should see the 935A AC Ammeter indicate some current between 0 and 10 amps.

3.1.3 Calculating Burden

When increasing the Drive Current on the Model 935A, you may not see the AC Ammeter indicate anything if the burden is too high. For example, *with a purely resistive burden of 1 ohm*, the maximum secondary current capacity of the 935A is only 29 amperes. Thus, the primary current would not be noticed on the Drive Current meter.

Since power (P) in Watts is defined as follows:

$$(3.1) \quad P = I^2 \times R,$$

Using the maximum available output power of 840 Watts in the 935A and relating it to secondary burden as follows:

$$(3.2) \quad I = \sqrt{\frac{840}{R}}$$

Inserting the referenced value for burden, R = 1 ohm, the calculated current in amperes is:

$$(3.3) \quad I = \sqrt{\frac{840}{1}} = 29 \text{ A}$$

3.1.4 Other Burden Calculations

Calculating burden can be very complicated with all of the uncertainties of wire orientation, connections, etc. Considering the same *purely resistive burden* as described above, and calculating the maximum available current for 0.1 and 0.01 ohm burdens, the maximum current would be about 90 and 290 amperes respectively. In practice, you must consider the capacitive and inductive reactive components (X_c and X_L). The overall burden for the secondary loop could be given by equation 3.4. Coil resistance would be the sum of the wire cross section, type of material and length, the connectors and the contact resistance between interconnections.

$$(3.4) \quad Z = R_L + Z_L = R_L + X_L + X_C$$

The inductive reactance (X_L) for a large gauge wire of three turns and diameter of 12 inches would be about 0.0014 ohms. With a real (i.e. resistive) component of about 0.01 ohms the total output current would be about 300 amperes. This is close to what we measured with the Model 931A. Together, the overall inductance could be computed or measured. To calculate the inductance for the coil in the example above would be as shown in equation 3.5.

$$(3.5) \quad L(\mu H) = \frac{d^2 n^2}{18d + 40l}$$

where

- L = inductance in microhenrys
- d = coil diameter in inches
- l = coil length in inches
- n = number of turns

Calculating, $L = 3.86\mu H$. Note that this value should not be taken as highly accurate as the coil diameter (d) and length (l) were not precise. Neither were the turns completely adjacent nor the diameter consistent. Equation 3.6 will give the inductive reactance for the coil at 60 Hz.

$$(3.6) \quad X_L = 2\pi fL$$

Where

- $\pi = 3.14159 \dots$
- f = the nominal frequency
- L = coil inductance from equation 3.5

Calculating, $X_L = 0.001451$ ohms.

Capacitive reactance (X_c) in a coil consists of the distributed capacitance that exists between adjacent turns of wire in a coil as illustrated in Figure 3.2. In practice this value would most likely be very small and could be ignored in any calculation to determine current.

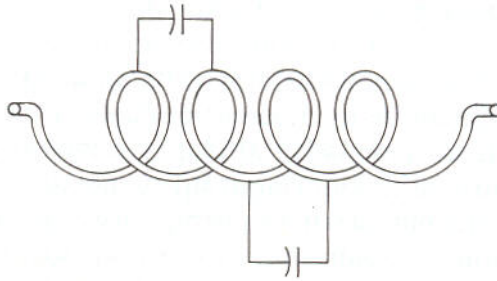

Figure 3.2: Distributed Capacitance in a Coil

3.1.5 Burden in Practice

In practice, the best solution is to keep all the interconnections very short, use the heaviest gauge wire possible and make all the connections secure by using smooth, flat, wide connectors, and tighten down all bolts. The overall burden from the example above may be fairly close, however the contributed resistance and inductive reactance may be off. The reactance may actually be lower and the resistance higher.

3.1.6 Setup Example

The photo in Figure 3.3 shows how the three instruments were set up as in Figure 3.1 to obtain about 300 amperes of secondary current through the large loop of cable. Note that three turns of this cable pass through the two CT's. To increase the current would require shorter cables, better connectors and larger cables.



Figure 3.3: Photo of Setup in Example

3.1.7 Calibrating Instrument Current Transformers

More sophisticated arrangements using the Model 935A are possible for calibrating instrument CT's, and are described in the Model 936A Operation Manual. Please see that publication for further discussion on that topic.