



**CALIBRATING METERS AND TRANSDUCERS
WITH THE MODEL 1040C
PANEL METER CALIBRATOR**

ARBITER SYSTEMS, INC.
1324 VENDELS CIRCLE, SUITE 121
PASO ROBLES, CA 93446
(805) 237-3831 FAX (805) 238-5717

PD0010800A 9-92

Introduction	1
Using the 1040C for Calibrating Single Phase Devices.....	2
A.C. Voltage.....	2
A.C. Current	2
A.C. Power	3
A.C. Frequency	3
Phase Angle.....	4
Power Factor	4
Volt-Amps and Volt-Amps Reactive	5
Using the 1040C for Calibrating Polyphase Devices.....	7
A.C. Voltage.....	7
A.C. Current	7
A.C. Power	7
Phase Angle.....	8
Power Factor	8
Volt-Amps and Volt-Amps Reactive	10
Calibrating Transducers Using the Null Comparison Method.....	11
Connection Diagrams	12
Phase, Power Factor, and VAR Convention Diagram	23
Appendix A: Meter Examples.....	24

Calibrating Meters and Transducers with the Arbiter Systems 1040C Panel Meter Calibrator

Introduction

Because of the variety of parameters involved, in-house and field calibration of meters and transducers used in the power industry has in the past required several specialized instruments. The Arbiter Systems Model 1040C Panel Meter Calibrator has incorporated all of the necessary functions into a single portable unit, designed specifically for the task. The purpose of this document is to provide a guideline for using the 1040C to calibrate commonly used meters and transducers.

The 1040C Panel Meter Calibrator is used by service and calibration professionals in the power generation and distribution fields, to measure and/or insure the accuracy of various meters and transducers used in generating facilities and substations. The instrument is also used by the U.S. Navy, to perform similar calibrations on equipment used for shipboard power generation and distribution.

The 1040C Panel Meter Calibrator can be configured to perform eight calibration functions:

- Voltage (ac and dc);
- Current (ac and dc);
- Frequency;
- Power;
- Power Factor;
- Phase;
- VARs;
- Synchroscope.

A front panel keyboard and display allow direct selection of values for all of the parameters shown above. Entered values can

be further modified using a knob also located on the front panel. A percent deviation key provides a simple method of determining the percentage of error for the meter or transducer under test. An internal memory allows storage of up to 99 instrument configurations for repetitive calibration tasks. Many of the operations performed via the front panel can be duplicated using the included hand-held control unit. Devices which operate within the following ranges can be calibrated with the 1040C:

- A.C. Voltage: 1.5 Vrms to 750 Vrms.
- A.C. Current: 0.1 Arms to 7.5 Arms.
- D.C. Voltage: 0.01 Vdc to 1000 Vdc.
- D.C. Current: 0.1 mAdc to 10.5 Adc.
- Frequency: 50 Hz to 75 Hz, 333 Hz to 500 Hz.
- A.C. Power: 1.5 VA to 5625 VA.
- Power Factor: 0.0 to 1.0, lead or lag.
- Phase: +180 to -180 degrees.
- VARs: 1.5 VA to 5625 VA.
- Synchroscope: Selection between 0 and 180 degrees.

Using the 1040C for Calibrating Single Phase Devices

A.C. Voltage

Representative schematics are given in figure 1 for typical circuit installations of single phase ac voltage meters and transducers. Connection of these instruments to the 1040C for calibration is a very simple process, illustrated in figure 2. The 1040C current output leads are not used, and can be left disconnected. The voltage output leads should be connected to the voltage input of the meter or transducer (figures 2a, 2c). If the meter or transducer uses an external potential transformer, it must be inserted between the 1040C voltage output leads and the input voltage leads of the unit under test (see Figure 2b, 2d). The user should then select the proper operating frequency, either 60 Hz or 400 Hz, and press the "Voltage" key to put the instrument into the voltage output mode. The desired voltage should then be entered, using the keypad, followed by the appropriate units. After this is completed, pressing the "Operate" key will enable the voltage output, which will increase to the value entered. An equal sign on the front panel display indicates that the output voltage has stabilized at the desired value. The calibration procedure for the meter or transducer under test can then be performed. For more complete instructions on operation of the 1040C in the ac voltage mode, refer to section 2.5.3 of the operation manual.

A.C. Current

Calibration of a single phase transducer or meter for ac current follows virtually the same process as for ac voltage meters and transducers, except that only the current output of the 1040C is used, rather than only the voltage output. Representative schematics are given in figure 3 for typical circuit installations of single phase ac current

meters and transducers. Connection of these instruments to the 1040C for calibration is illustrated in figure 4. The 1040C voltage output leads are not used, and can be left disconnected. The current output leads should be connected to the current input of the meter or transducer (figures 4a, 4c). If the meter or transducer uses an external current transformer, one output lead of the 1040C should be routed through the center of the current transformer and connected to the other lead (see Figure 4b, 4d). The user should then select the proper operating frequency, either 60 Hz or 400 Hz, and press the "Current" key to put the instrument into the current output mode. The desired current should then be entered, using the keypad, followed by the appropriate units. After this is completed, pressing the "Operate" key will enable the current output, which will increase to the value entered. An equal sign on the front panel display indicates that the output current has stabilized at the desired value. The calibration procedure for the meter or transducer under test can then be performed. For more complete instructions on operation of the 1040C in the ac current mode, refer to section 2.5.5 of the operation manual.

A.C. Power

Typical circuit connections for single-phase ac watt meters and transducers are given in figure 5. Calibration of these types of devices requires use of both the voltage and current outputs of the 1040C. Representative calibration connection diagrams for these types of devices are given in figure 6. The 1040C voltage output leads are connected to the voltage terminals of the meter or transducer, and the 1040C current output leads are connected to the current input terminals of the meter or transducer (figures 6a and 6c). If the meter or transducer uses an external current transformer, one of the current output leads of the 1040C should be passed through the center of the current transformer, and then shorted to the other lead. If the meter or transducer uses an external potential transformer, then likewise it must be inserted between the 1040C voltage output leads and the input voltage leads of the unit under test. Refer to figures 6b and 6d for these connections. The user should then select the proper operating frequency, either 60 Hz or 400 Hz. The "Power" key should be pressed, which will place the 1040C into the power mode, enabling both the voltage and current outputs for simultaneous operation. The "Voltage" key should then be pressed, and the desired voltage entered using the keypad, followed by "V". After this, the "Current" key should be pressed and the desired current entered using the keypad, followed by "A". After this is completed, pressing the "Operate" key will enable the outputs, which will increase to the respective values entered. An equal sign on the front panel display indicates that the current and voltage outputs, and the phase angle between them, have stabilized at the proper values. The calibration procedure for the meter or transducer under test can then be performed. The power value can be varied using the control knob or the up/down arrows, but it is

important to note that it is only the current that changes; the voltage remains constant. For more complete instructions on operation of the 1040C in the ac power mode, refer to section 2.5.6 of the operation manual.

A.C. Frequency

Calibration of ac frequency is another procedure that requires the use of only the 1040C voltage output. The connections are the same as for the volt meter or transducer (Figure 2). After connection, the frequency range (i.e. 60Hz, 400Hz) is selected, then "Voltage" is pressed. The operator then enters the voltage value which is appropriate for the device under test, followed by the voltage unit key. Fine adjustment of the frequency can be accomplished by first pressing the "Frequency" key, then using the adjust knob or up/down keys to select the value. A value for frequency can also be entered via the keyboard, by first pressing "Frequency", entering the value, then pressing the "Hz" key. When the "Operate" key is pressed, the voltage output will be enabled and the calibration procedure for the device under test may be performed. For more complete instructions on frequency operation of the 1040C, refer to section 2.5.8 of the operation manual.

Phase Angle

Calibration of phase angle meters or transducers for single phase operation requires use of both the voltage and current outputs of the 1040C. The representative circuit connection diagrams for these types of devices are the same as for the ac power meters and transducers, given in figure 5. Typical connections for calibration are also the same as for ac power meters and transducers, and are given in figure 6. For calibration, the 1040C voltage output leads are connected to the voltage terminals of the meter or transducer, and the 1040C current output leads are connected to the current input terminals of the meter or transducer (figure 6a and 6c). If the meter or transducer uses an external current transformer, one of the current output leads of the 1040C should be passed through the center of the current transformer, and then shorted to the other lead. If the meter or transducer uses an external potential transformer, then likewise it must be inserted between the 1040C voltage output leads and the input voltage leads of the unit under test. Refer to figures 6b and 6d for these two types of connections. The 1040C should first be configured to operate in the ac power mode, as described in paragraph 2.5.6, and the appropriate voltage and current values should be selected. After the outputs have been enabled and the phase angle meter or transducer under test has been observed to be indicating zero, press the "Phase" button. This will allow shifting of the relative phase between the voltage and the current outputs. The desired phase angle can now be entered directly, via the keypad, and followed by the appropriate units (degrees). A negative value for phase angle corresponds to the output current lagging the output voltage. After entering the value for phase angle, the operator may adjust the value by using the control knob, or by using the "Up" or "Down" keys. For more complete instructions on operation of the

1040C for phase angle calibrations, refer to section 2.5.1 of the operation manual.

Power Factor

The Power Factor in a circuit is equal to the cosine of the phase angle between the voltage and the current. With this in mind, any power factor can be simulated by adjusting the phase relationship between the voltage and current, which can be accomplished quite easily with the 1040C. Two methods can be used:

- The required phase angle can be entered directly via the keypad, as described in the section on phase angle calibration;
- The power factor can be entered directly, by first pressing the "Power Factor" key, then using the adjust knob to vary the displayed power factor. This method allows entry of lead or lag power factor values without having to first calculate the corresponding phase angle.

For an illustration of the relationship between phase angle and power factor in the 1040C, refer to figure 12.

In order to accomplish power factor indication, some transducer manufacturers recommend using one of their phase angle transducers and performing a mathematical conversion on the output signal. This can be done manually, using conversion tables supplied by the manufacturer, or automatically, using a meter having cosine scaling. Typical transducer application circuit connections and calibration setup connections are usually the same as those for a phase angle, watt, or var transducer, as shown in figures 5 and 6. Calibration can be performed using the connections in figure 6 and one of the methods outlined above, and in accordance with the transducer manufacturers recommendations.

Power factor output is also commonly available as an additional feature on single

and multi-phase watt transducers. In this case, the transducer is connected in the same manner as a conventional watt transducer (refer to figures 5 and 6).

Typical applications of power factor *meters* for single-phase systems involve circuit connections which are similar, if not identical to those employed by single phase watt and var meters. In light of this, representative circuit and calibration connection diagrams for these meters are shown in figures 5 and 6. When connected per the calibration setup diagram, calibration of single-phase power factor meters can be performed using one of the methods given above, and in accordance with the meter manufacturer's recommendations. For more detailed instructions on operating the 1040C for calibration of power factor, refer to section 2.5.1 of the operation manual.

Volt-Amps and Volt-Amps Reactive

Volt-Amps is the product of the rms voltage and the rms current in a circuit, without regard to the phase angle between them. Another term commonly used to describe this parameter is *apparent power*. If a separate rms ammeter and rms voltmeter were used to measure the current and voltage, respectively, and the two values were multiplied together, the result would be the apparent power. This is not an indication of the amount of work that can be done, however; if the phase angle is 90 degrees (power factor is zero), the true power available is zero.

Volt-amps reactive (SI unit=var) is the same as volt-amps, but with the phase angle between voltage and current factored in. Vars are a measure of the amount of power required by the reactive portion of a load, and actually represents circulating current in the circuit. Vars are calculated as the product of the RMS voltage, the RMS current, and the sine of the phase angle

between the two. For an illustration of the relationship between phase angle and vars when using the 1040C, refer to figure 12.

The 1040C has a provision for displaying and modifying both volt-amps and vars; successively pressing the "Power" key during operation will first display watts, then vars, then volt-amps. The user can continue indefinitely to scroll through these three choices.

Some points of interest regarding va and var measurements:

It is important to note that unless there is a phase angle of greater than zero between voltage and current, the var value will be zero. Also, since va and var indications are sub-functions of the power mode, adjustment of these values using direct entry, the control knob, or the up/down keys affects the value by changing *only the current*, not the voltage or the phase angle. The current can only be modified to a point within the current range of the 1040C. If the necessary current exceeds this range, the display will indicate "Entry Error". Additionally, if the phase angle is set to zero and the user attempts to enter any var value other than zero, "Entry Error" will be indicated. This is because under these conditions, no value of voltage or current will produce anything other than zero vars.

Typical applications of va and var meters or transducers for single-phase systems involve circuit connections which are similar, if not identical to those employed by single phase watt and power factor meters and transducers. Therefore, representative circuit connections and calibration connections for these devices are shown in figures 5 and 6, respectively. When connected per the calibration setup diagram, calibration of these instruments can be performed in accordance with the meter manufacturer's recommendations. For more

detailed instructions on operating the 1040C in the volt-amps and volt-amps reactive modes, refer to section 2.5.6 of the operation manual.

Using the 1040C for Calibrating Polyphase Devices

A.C. Voltage

Commercially available multi-phase voltage transducers frequently consist of more than one single-phase model from the manufacturers product line, repackaged into a common enclosure. In many cases, the outputs remain separate and independent. The procedure for calibration of these types of transducers is virtually identical to that of the single-phase voltage transducer. The three elements can be connected in parallel across the voltage output of the 1040C, as shown in figure 7a, provided that the combined current demand of the elements does not exceed the burden capability of the 1040C (refer to table 1.2 in the operation manual). Multiple voltmeters may also be connected to the 1040C in the same manner, as shown in figure 7b, with the same total current burden restriction.

A.C. Current

Like their ac voltage counterparts, commercially available multi-phase current transducers frequently consist of more than one single-phase model from the manufacturers product line, repackaged into a common enclosure. In many cases, the outputs remain separate and independent. The procedure for calibration of these types of transducers is nearly identical to that of the single-phase current transducer. The three elements can be connected (in series) across the current output leads of the 1040C, as shown in figure 8a, provided that the combined voltage drop across the elements does not exceed the burden capability of the 1040C (refer to table 1.1 in the operation manual). Multiple current meters may also be connected to the 1040C in the same manner, as shown in figure 8b, with the same total voltage burden restriction.

A.C. Power

Power measurement in a three-phase, four-wire system requires three complete watt meters or watt transducers (each watt meter or transducer consists of one current element and one voltage element). Figure 9a shows a typical connection diagram for measurements of this type. A current sensing element is placed in series with each of the three phases, and a voltage sensing element is connected between each of the phases and the neutral wire. It is unnecessary to measure the neutral current directly, since any current flowing in the neutral conductor will be simultaneously flowing in one or more of the phases and will thus be measured.

Power measurement in a three-phase, *three*-wire system requires *two* complete watt meters or watt transducers. Figure 9b shows a connection diagram for this type of measurement. Again, the number of current elements required is equal to one less than the number of current-carrying conductors, since any current in the non-instrumented conductor must simultaneously be flowing in one or both of the others. The voltage elements are connected to the two phases having the current elements, with the common point for the voltage elements being the third phase.

Calibration of multi-element watt transducers or meters can be accomplished using the setup shown in figure 10. Basically, all of the current elements would be connected in series and placed across the current output of the 1040C, and all of the voltage elements would be connected in parallel and placed across the voltage output of the 1040C. Again, current and potential transformers are shown for reference. Phasing of the elements is of great

importance for accuracy of the calibration. All current elements should be wired the same way, and all voltage elements should be in phase. The only exception to this rule would be for 2 1/2 element transducers, which are sometimes used in order to save the cost of one potential transformer. The missing potential input is accounted for mathematically, so during calibration one of the current transformers must be reversed, and special calculations apply. When calibrating 2 1/2 element transducers, the product documentation for the device should be consulted for proper procedures.

Phase Angle

Wiring connections for phase angle transducers used in three-phase systems at first glance may appear somewhat unorthodox. Typically, a single voltage element and a single current element are used. The current element is placed in series with one of the phases, or, if used, a current transformer is placed around the conductor for that phase. The voltage element is wired between the remaining two phases, sometimes employing a potential transformer. Refer to figure 11a for a typical application circuit. If the phase angle between the voltage and the current in the circuit is zero, the net voltage between the two measured phases (or the output voltage of the potential transformer) will be offset from the current measured in the third phase by 90 degrees. The two input signals are compared internally, and a dc voltage corresponding to the phase angle is output from the transducer.

Connections for use of a 1040C to calibrate this type of phase angle transducer are shown in figure 11b. The 1040C voltage output leads are connected to the voltage terminals of the transducer, and the 1040C current output leads are connected to the current input terminals of the meter or transducer. If the transducer uses an external

current transformer, one of the current output leads of the 1040C should be passed through the center of the current transformer, and then shorted to the other lead. If the meter or transducer uses an external potential transformer, then likewise it must be inserted between the 1040C voltage output leads and the input voltage leads of the unit under test. The 1040C should first be configured to operate in the ac power mode, and the appropriate voltage and current values should be selected. Next, a calibration phase angle value must be entered, keeping in mind that for indication of zero phase from the transducer output, the input voltage must be offset from the input current by 90 degrees (whether this is a lead or lag condition depends on the individual transducer manufacturer. The calibration procedure for the phase angle transducer can now be performed. For more complete instructions on operation of the 1040C for phase angle calibrations, refer to section 2.5.1 of the operation manual.

Power Factor

In order to accomplish power factor indication, some transducer manufacturers recommend using one of their phase angle transducers and performing a mathematical conversion on the output signal. This can be done manually, using conversion tables supplied by the manufacturer, or automatically using a meter having cosine scaling. If a phase angle transducer is employed for this purpose, the connections will be the same as those illustrated in figure 11.

Power factor output is also commonly available as an additional feature on single and multi-phase watt transducers. In this case, the transducer is connected in the same manner as a conventional multi-phase watt transducer (refer to figure 9).

Regardless of the type of transducer or meter employed, the 1040C has a provision for direct calibration of power factor. As stated earlier in this document, the power factor in a circuit is equal to the cosine of the phase angle between the voltage and the current. With this in mind, any power factor can be simulated by adjusting the phase relationship between the voltage and current, which can be accomplished quite easily with the 1040C. Two methods can be used:

- The required phase angle can be entered directly via the keypad, as described in the section on phase angle calibration;
- The power factor can be entered directly, by first pressing the "Power Factor" key, then using the adjust knob to vary the displayed power factor. This method allows entry of lead or lag power factor values without having to first calculate the corresponding phase angle.

Calibration of the transducer should be performed according to the instrument manufacturer's recommendations.

Typical applications of power factor *meters* for multi-phase systems involve circuit connections which are similar, if not identical to those employed by multi-phase phase angle transducers. Generally, the current is measured in one phase, and a comparison is made between it and the net voltage between the remaining two phases. Substituting a meter for the transducers shown in figure 11 will give a good indication of the type of connections necessary for typical applications and calibration.

For more detailed instructions on operating the 1040C for calibration of power factor, refer to section 2.5.1 of the operation manual.

Volt-Amps and Volt-Amps Reactive

Refer to the single-phase volt-amps and volt-amps reactive section of this document for definitions of these parameters.

The 1040C has a provision for displaying and modifying both volt-amps and vars; successively pressing the "Power" key during operation will first display watts, then vars, then volt-amps. The user can continue indefinitely to scroll through these three choices.

Some points of interest regarding va and var measurements:

It is important to note that unless there is a phase angle of greater than zero between voltage and current, the var value will be zero. Also, since va and var indications are sub-functions of the power mode, adjustment of these values using direct entry, the control knob, or the up/down keys affects the value by changing *only the current*, not the voltage or the phase angle. The current can only be modified to a point within the current range of the 1040C. If the necessary current exceeds this range, the display will indicate "Entry Error". Additionally, if the phase angle is set to zero and the user attempts to enter any var value other than zero, "Entry Error" will be indicated. This is because under these conditions, no value of voltage or current will produce anything other than zero vars.

Typical applications of va and var meters or transducers for multi-phase systems involve circuit connections which are similar, if not identical to those employed by multi-phase watt and power factor meters and transducers. Therefore, representative circuit connections and calibration connections for these devices are shown in figures 9 and 10, respectively. When connected per the calibration setup diagram, calibration of these instruments can be

performed in accordance with the meter manufacturer's recommendations. For more detailed instructions on operating the 1040C in the volt-amps and volt-amps reactive modes, refer to section 2.5.6 of the operation manual.

Calibrating Transducers Using the Null Comparison Method

The null comparison method is frequently recommended by transducer manufacturers, since it eliminates many of the variables that can be encountered in the course of a conventional calibration. The basic procedure for performing a null comparison calibration is as follows: The inputs of a precision standard are connected in parallel with the inputs of the transducer under test, and the appropriate source voltages and/or currents are applied. A differential meter is connected between the outputs of the precision standard and the transducer under test, and the zero and span settings of the transducer under test are adjusted until the differential meter displays zero. The advantage of this method is that since the input signals are exactly the same, the accuracy of the source (and the equipment used to measure it) are inconsequential. The calibration accuracy is dependent only on the individual accuracies of the precision standard and of the differential meter.

Precision standards are usually available from the manufacturers of the transducers, and typically have accuracies of 0.1%. The disadvantage of using precision standards is that for each type of transducer to be calibrated, a different precision standard is required. Use of the 1040C eliminates the need for these various precision standards, since all of the necessary functions can be generated from one unit. Also, since the 1040C is a precision source and no external meters are necessary, the simplicity of the calibration procedure is about the same as that of the null comparison method.

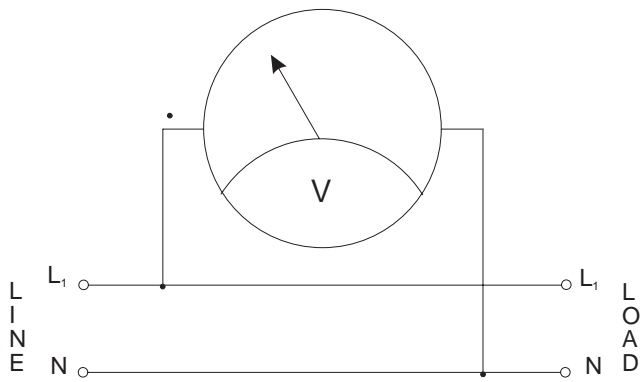

a) Voltmeter, Typical Installation, no Potential Transformer

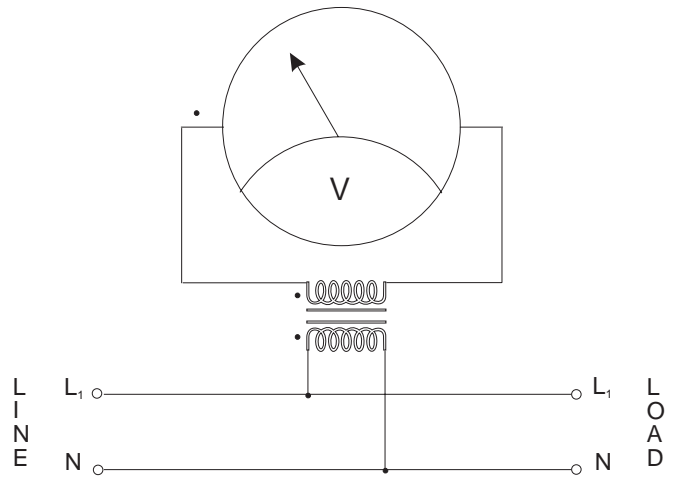

b) Voltmeter, Typical Installation, with Potential Transformer

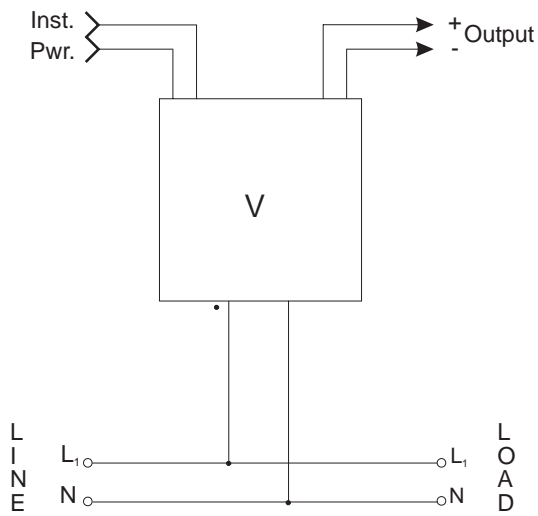

c) Voltage Transducer, Typical Installation, no Potential Transformer

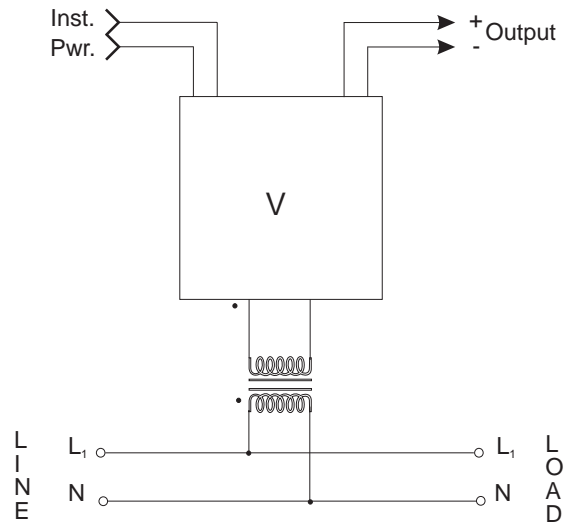

d) Voltage Transducer, Typical Installation, with Potential Transformer

Figure 1
Single-Phase Voltage Meters and Transducers,
Typical Circuit Connections

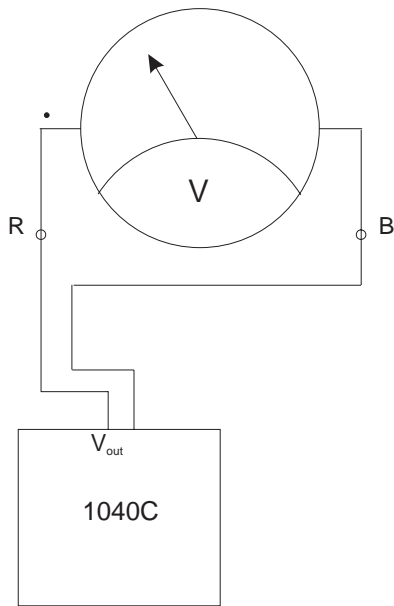

a) Voltmeter Calibration Connections, no Potential Transformer

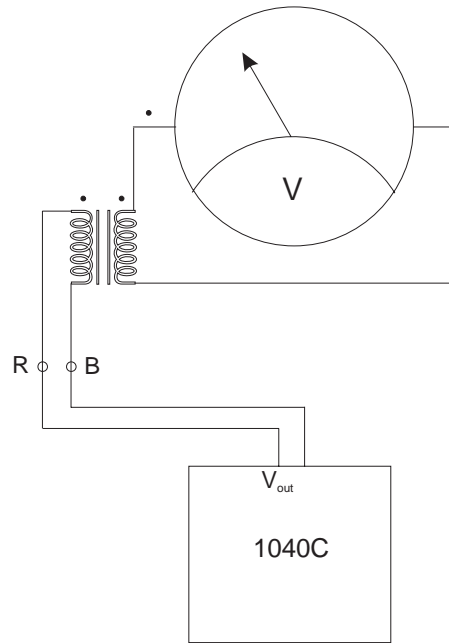

b) Voltmeter Calibration Connections, with Potential Transformer

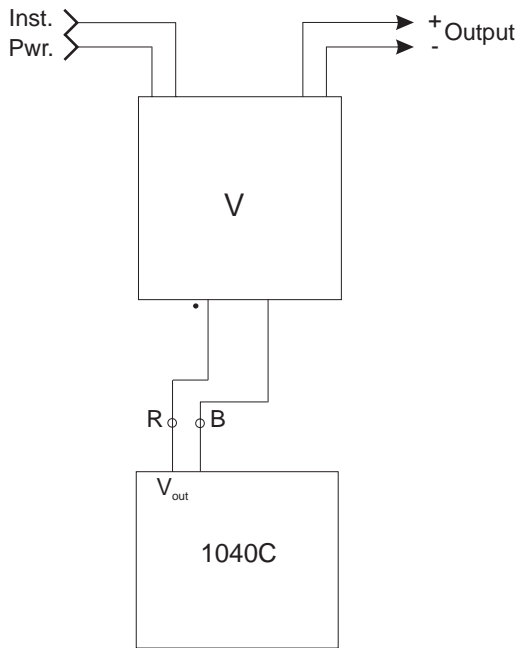

c) Voltage Transducer Calibration Connections, no Potential Transformer

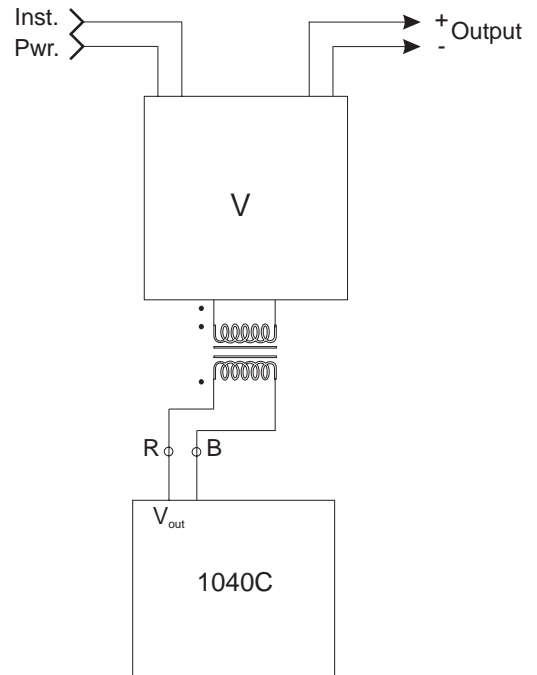

d) Voltage Transducer Calibration Connections, with Potential Transformer

Figure 2
Single-Phase Voltage Meters and Transducers,
Typical Circuit Connections

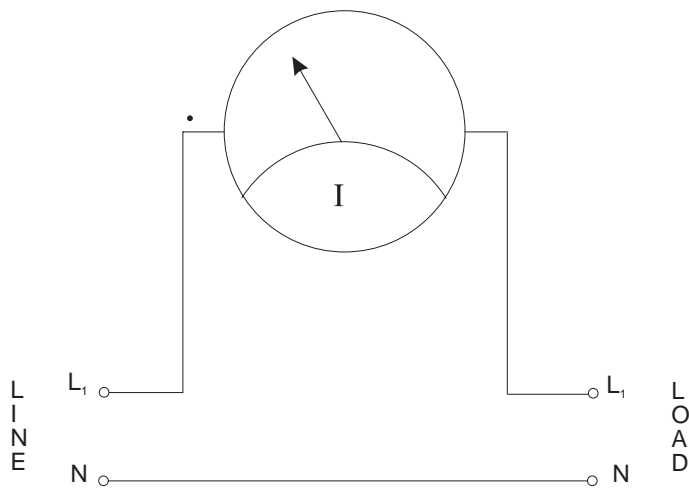

a) Current Meter, Typical Installation, no Current Transformer

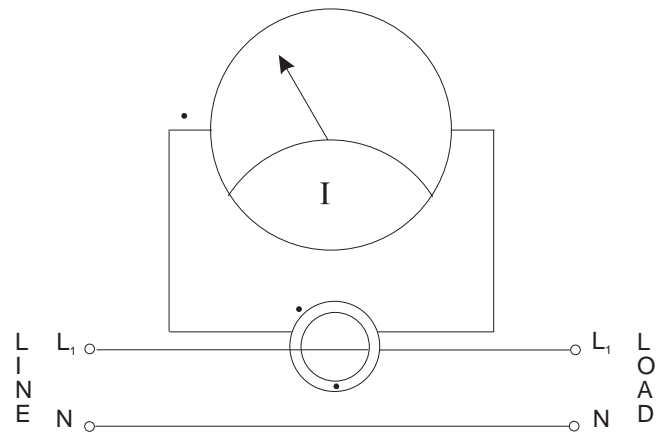

b) Current Meter, Typical Installation, with Current Transformer

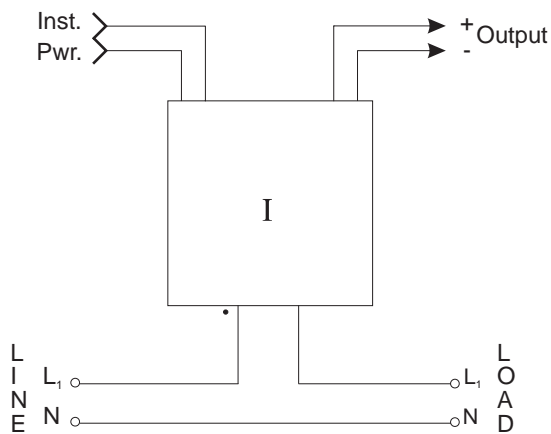

c) Current Transducer, Typical Installation, no Current Transformer

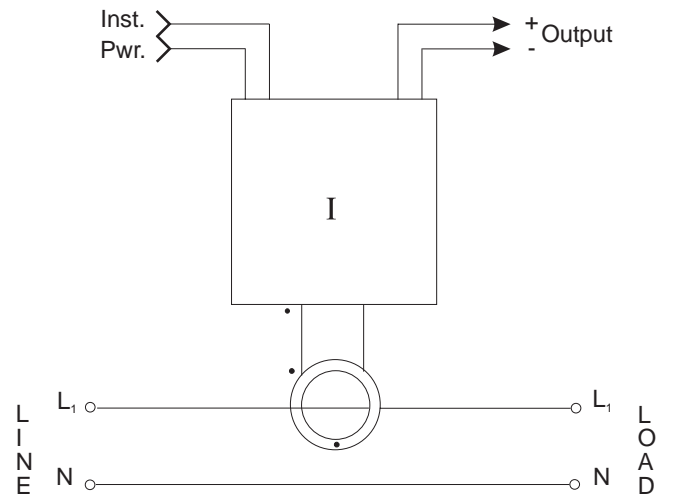

d) Current Transducer, Typical Installation, with Current Transformer

Figure 3
Single-Phase Current Meters and Transducers,
Typical Circuit Connections

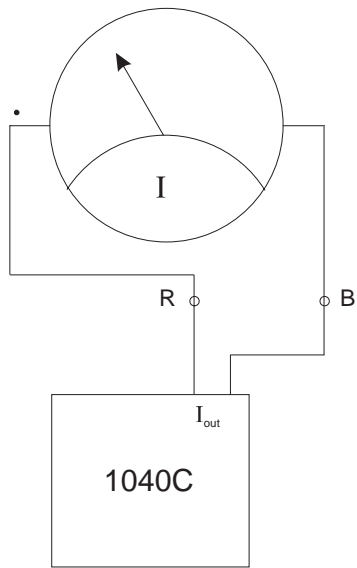

a) Current Meter Calibration Connections, no Current Transformer

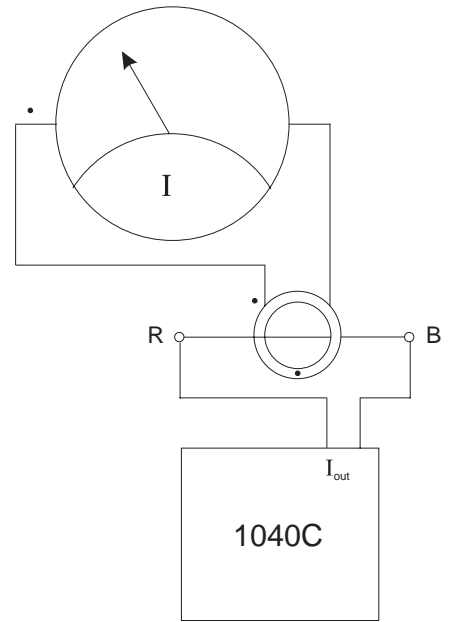

b) Current Meter Calibration Connections, with Current Transformer

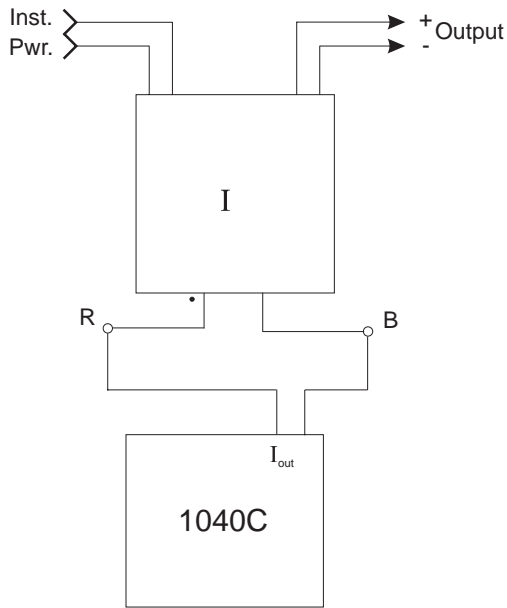

c) Current Transducer Calibration Connections, no Current Transformer

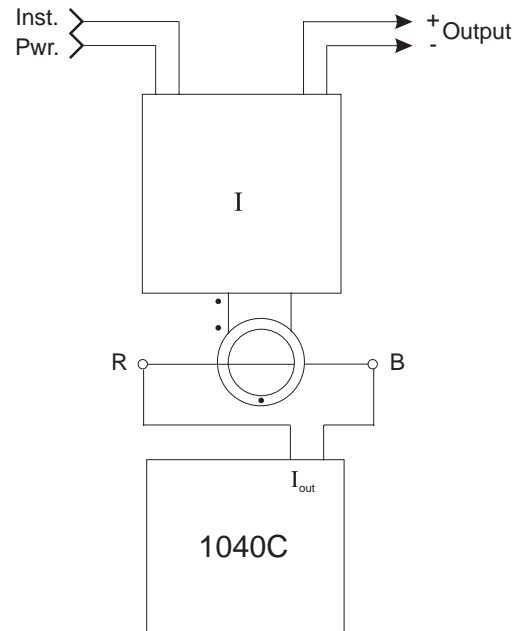

d) Current Transducer Calibration Connections, with Current Transformer

Figure 4
Single-Phase Current Meters and Transducers,
Calibration Connections

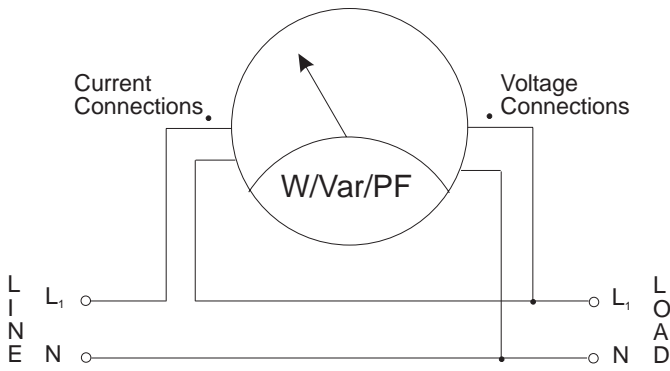

a) W/Var/PF Meter, Typical Installation, no Current or Potential Transformers

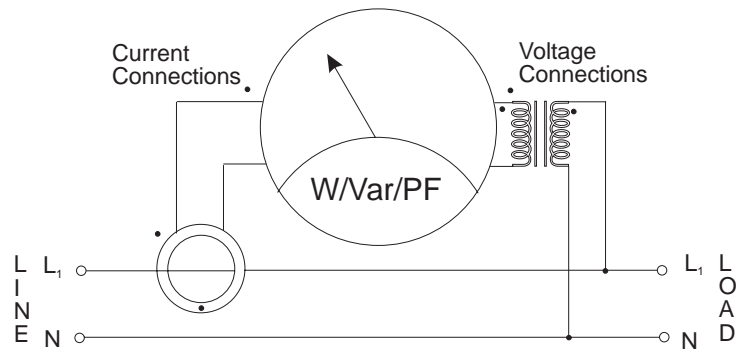

b) W/Var/PF Meter, Typical Installation, with Current and Potential Transformers

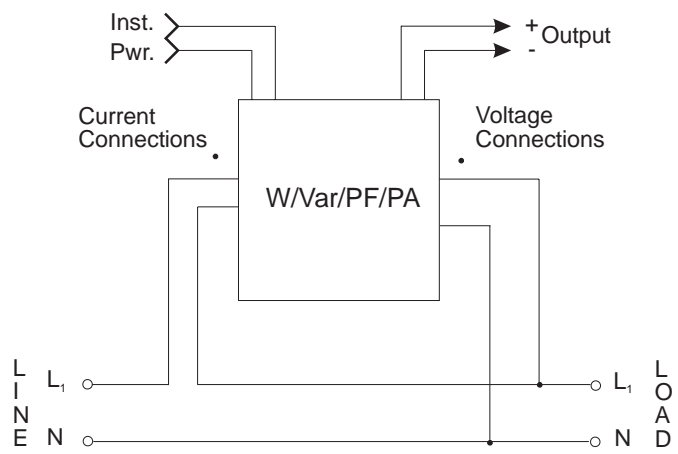

c) W/Var/PF Transducer, Typical Installation, no Current or Potential Transformers

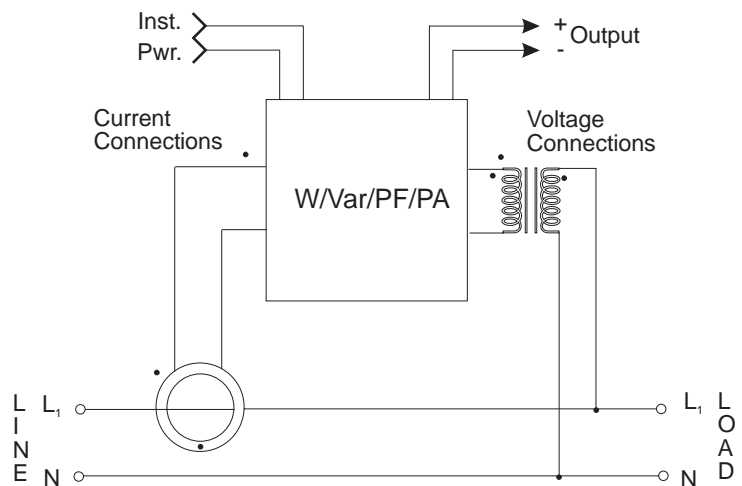

d) W/Var/PF/PA Transducer, Typical Installation, with Current and Potential Transformers

Figure 5
Single-Phase Watt, Var, or Power Factor Meters and
Watt, Var, Power Factor, or Phase Transducers,
Typical Circuit Connections

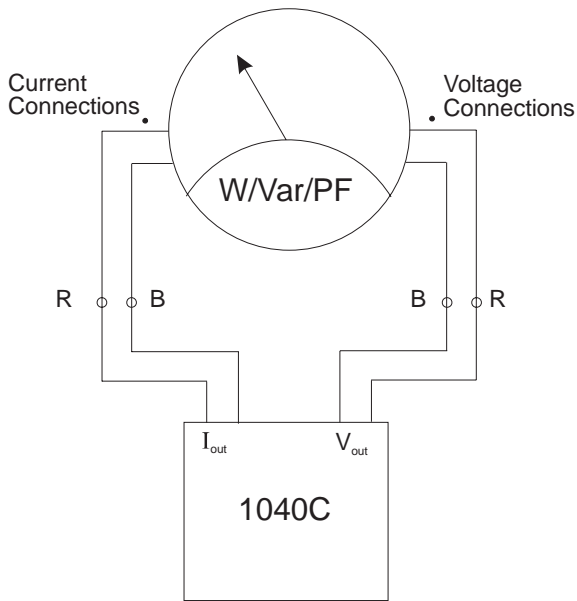

a) W/Var/PF Meter Calibration Connections, no Current or Potential Transformers

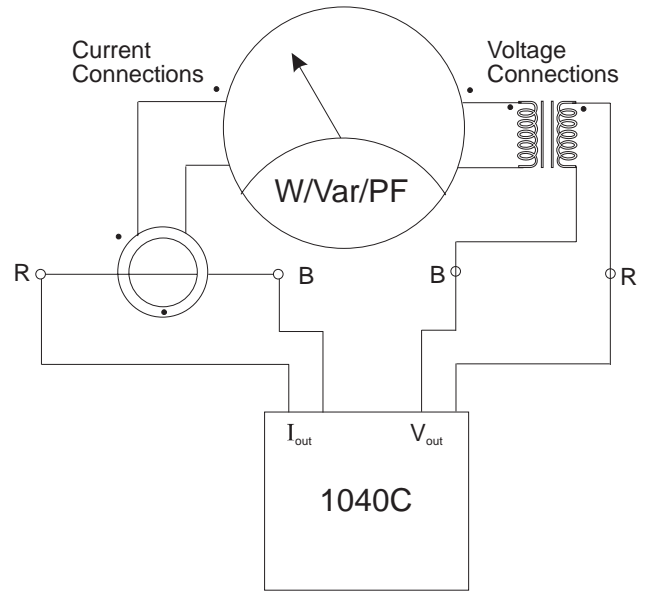

b) W/Var/PF Meter Calibration Connections, with Current and Potential Transformers

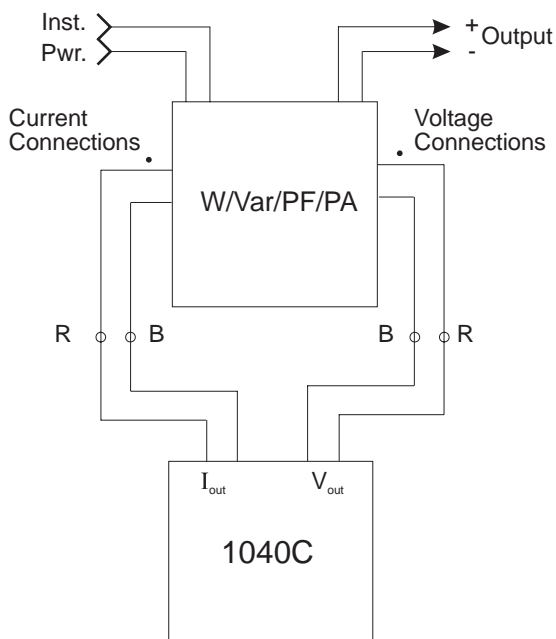

c) W/Var/PF/PA Transducer Calibration Connections, no Current or Potential Transformers

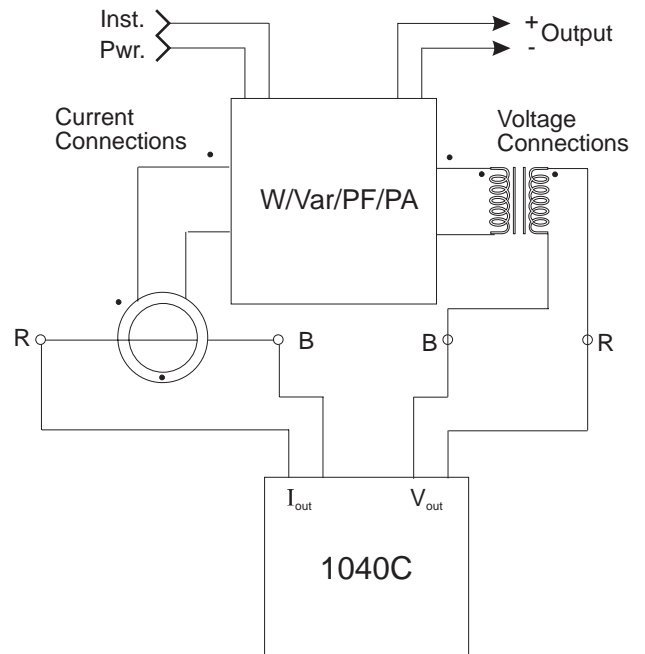

d) W/Var/PF/PA Transducer Calibration Connections, with Current and Potential Transformers

Figure 6
Single-Phase Watt, Var, or Power Factor Meters and
Watt, Var, Power Factor, or Phase Transducers, Calibration Connections

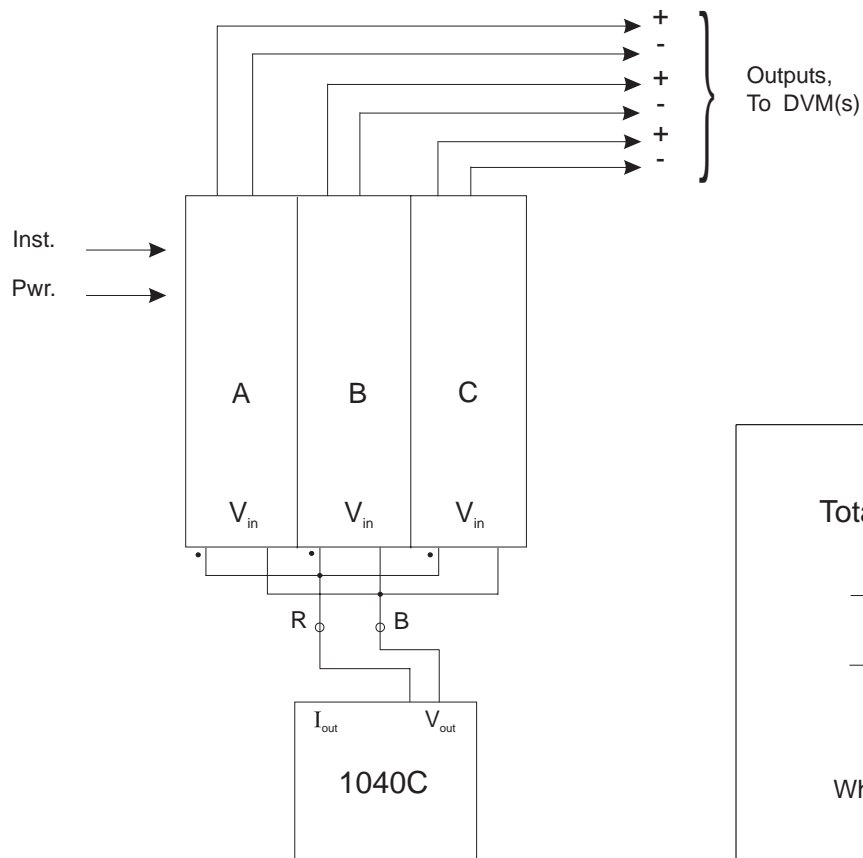

a) Transducers

Total Burden Current =

$$\frac{V}{\frac{1}{\frac{1}{Z_A} + \frac{1}{Z_B} + \frac{1}{Z_C} \dots}}$$

Where:

V= Output Voltage of 1040C

Z_x= Impedance of Transducer or Meter x, at Frequency of Operation

c) Burden Calculation

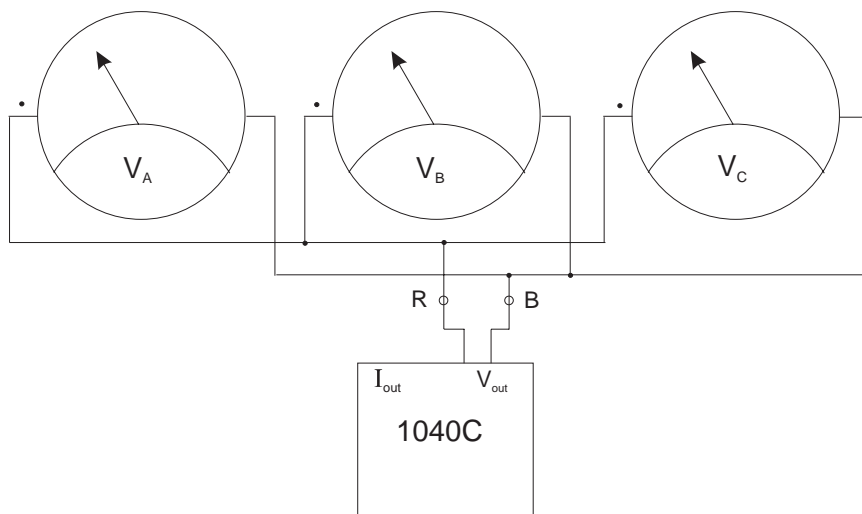

b) Meters

Figure 7
Calibration of Multiple Voltage Transducers or Meters

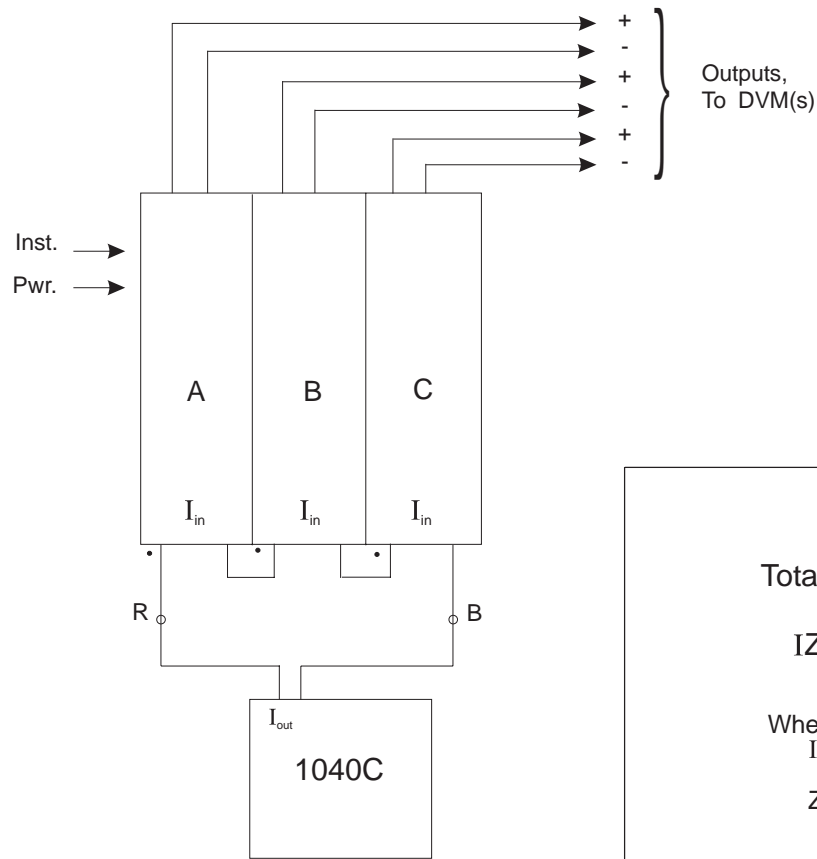

a) Transducers

Total Burden Voltage =

$$IZ_A + IZ_B + IZ_C \dots$$

Where:

I = Output Current of 1040C

Z_x = Impedance of Transducer x
at Frequency of Operation

c) Burden Calculations

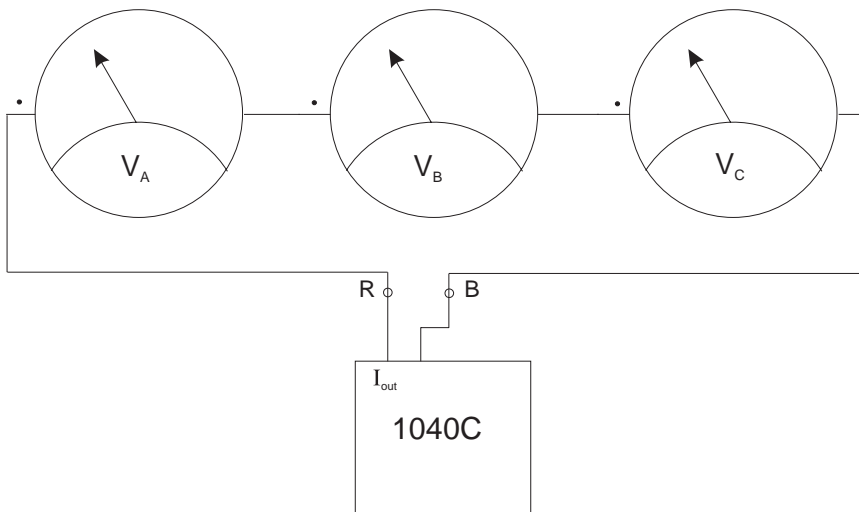

b) Meters

Figure 8
Calibration of Multiple Current Transducers or Meters

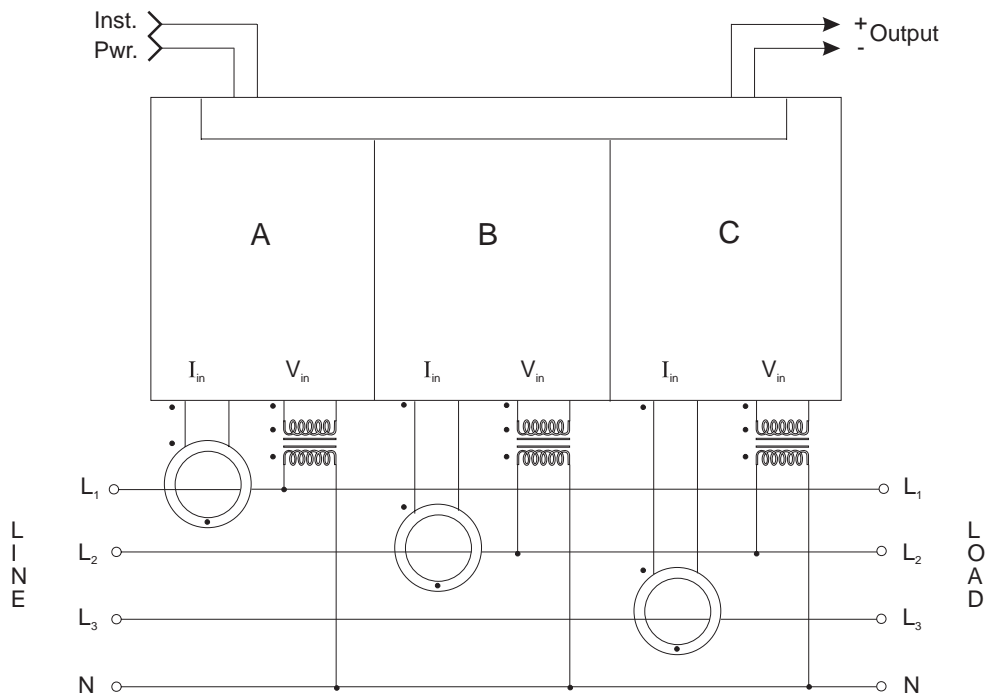

a) Circuit Connections for Power Measurement in a 3 Phase, 4 Wire System, using a 3-Element Transducer

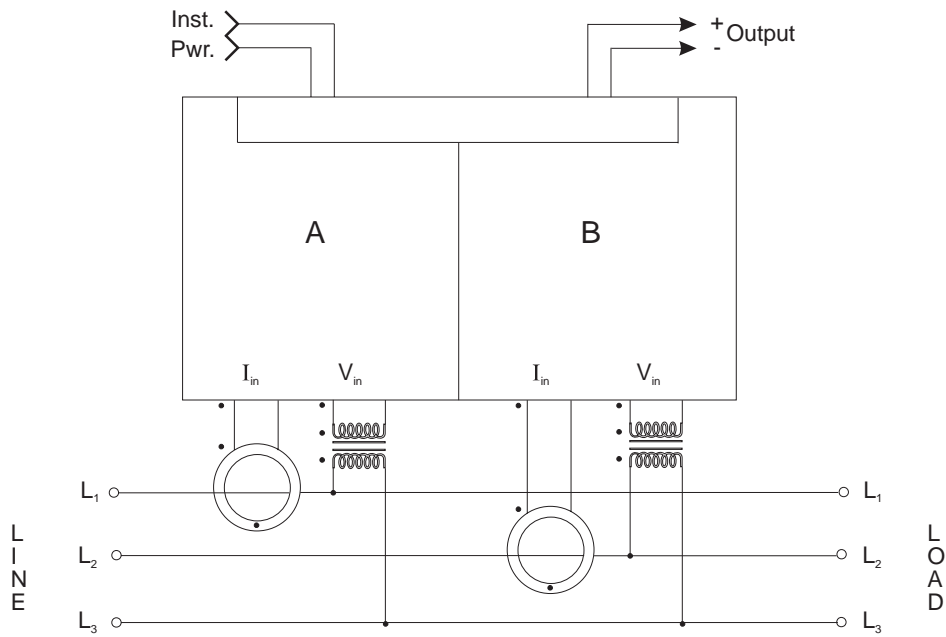

b) Circuit Connections for Power Measurement in a 3 Phase, 3 Wire System, Using a 2-Element Transducer

Figure 9
Multi-Phase Power Measurement Techniques

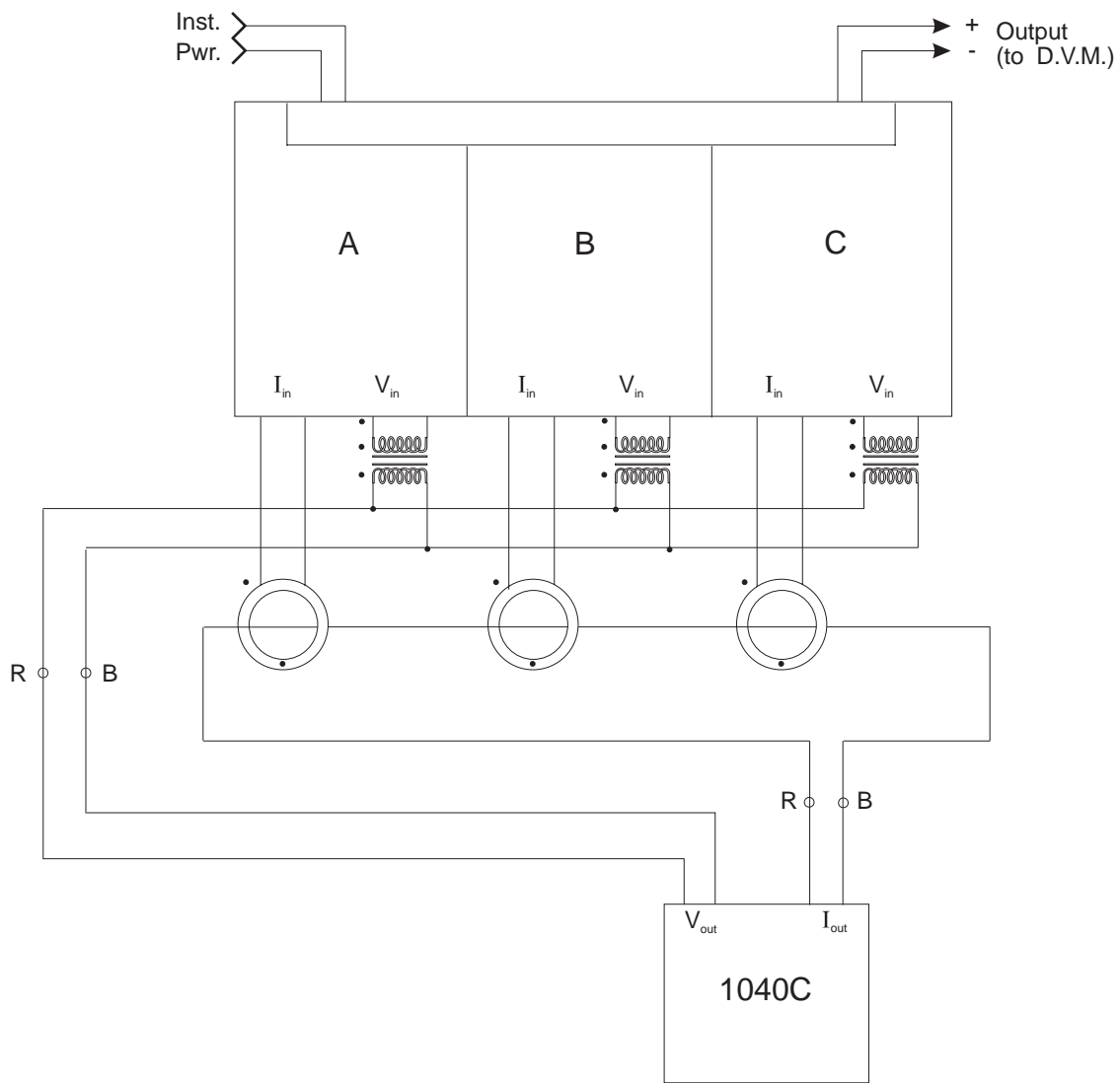
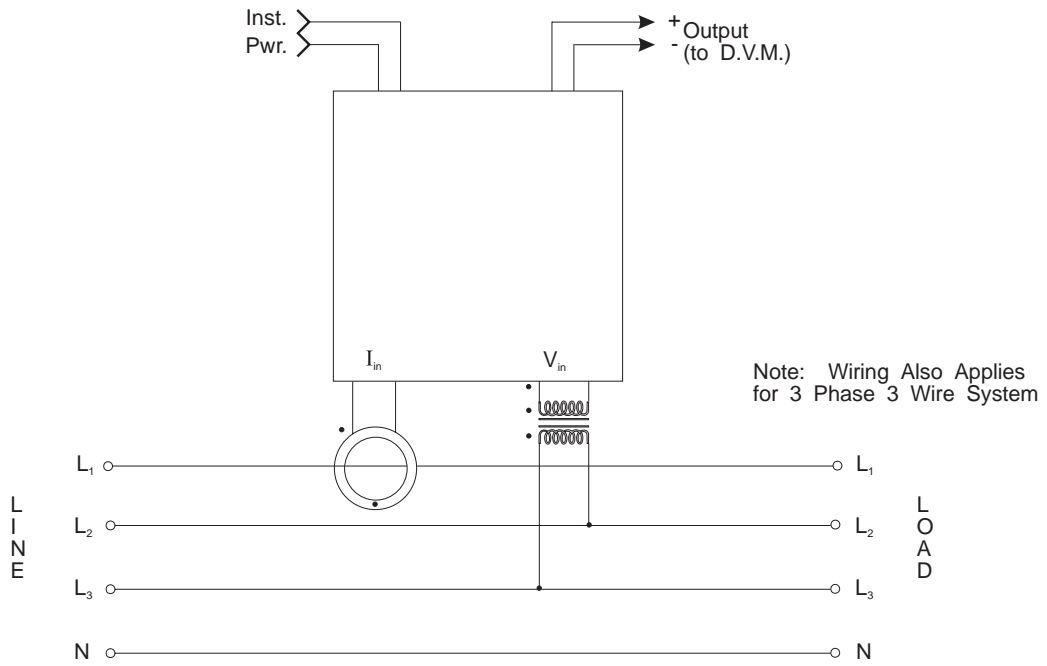
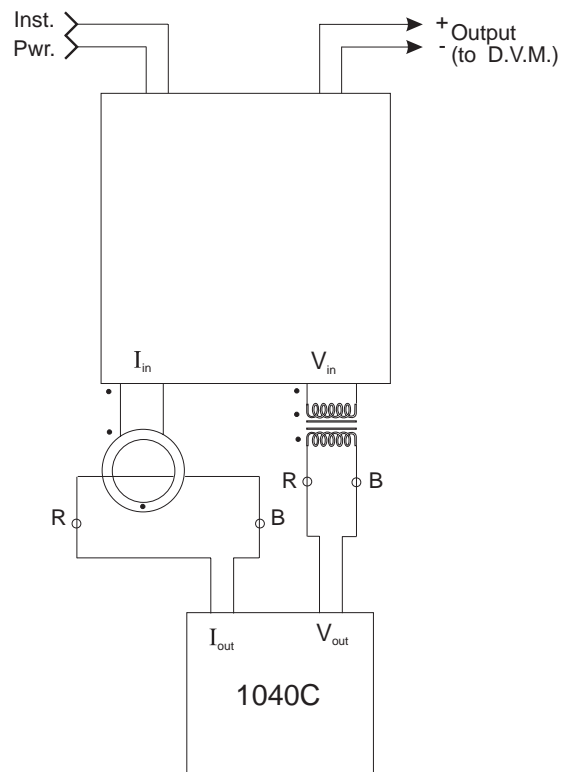

Figure 10
Calibration Connections for 3-Element Watt Transducer.
Current and Potential Transformers are included for reference.



a) Typical Circuit Connections



b) Typical Calibration Connections

Figure 11
Phase Angle Transducer

Current Leads Voltage

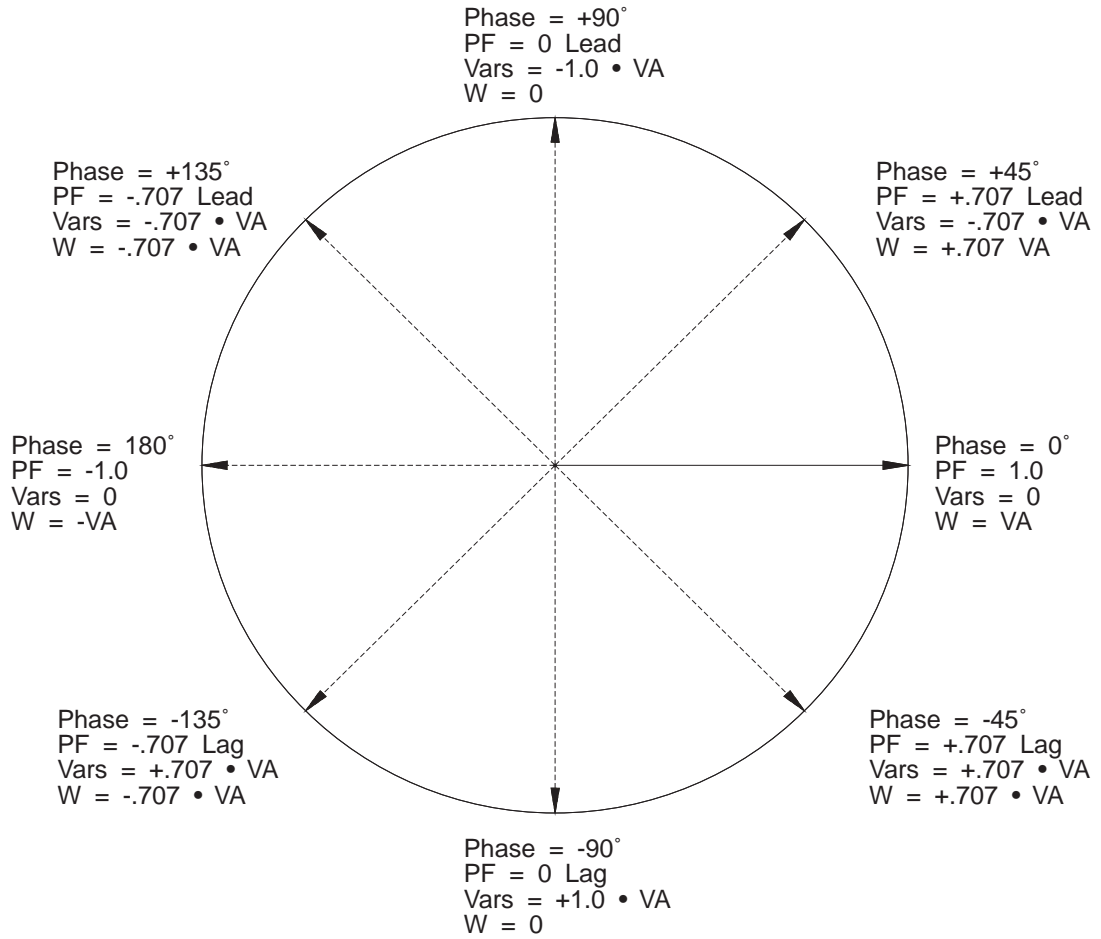

Voltage Leads Current

Conventions Used in the 1040C:

Power Factor = $\text{Cos } \theta$
 Vars = $V_{\text{rms}} \cdot I_{\text{rms}} \cdot \text{Sin } (-\theta)$
 Watts = $V_{\text{rms}} \cdot I_{\text{rms}} \cdot \text{Cos } \theta$
 VA = $V_{\text{rms}} \cdot I_{\text{rms}}$

Where: θ (Theta) = Phase Angle between voltage and current. A negative number indicates that current is lagging voltage.

Example:

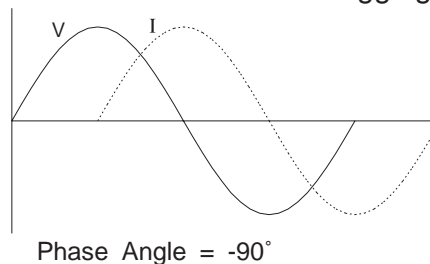
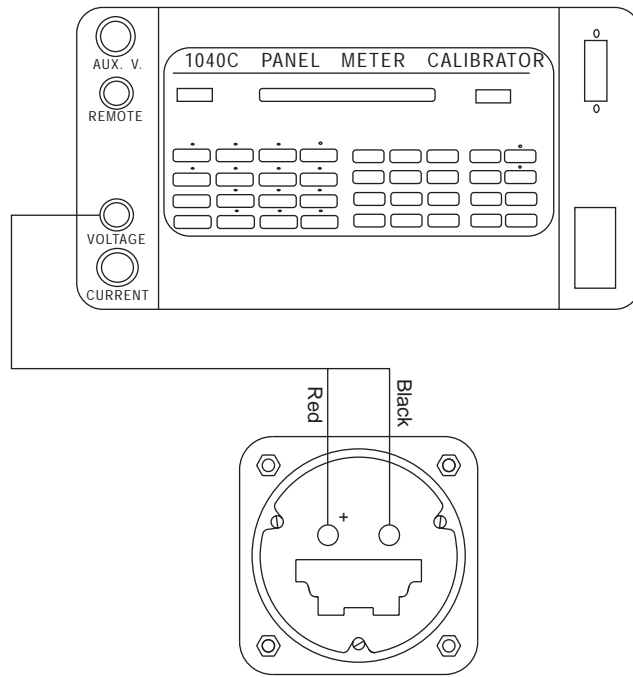

Figure 12
 Phase, Power Factor, and VAR Conventions
 Employed by the 1040C Panel Meter Calibrator

Appendix A

Meter Examples

The following pages contain connection diagrams for use in calibrating various types of Yokogawa panel meters. These illustrations are for reference only; the manufacturer's data sheets should be consulted to insure proper connections.



**AC VOLTMETER
YOKOGAWA 103021**_____

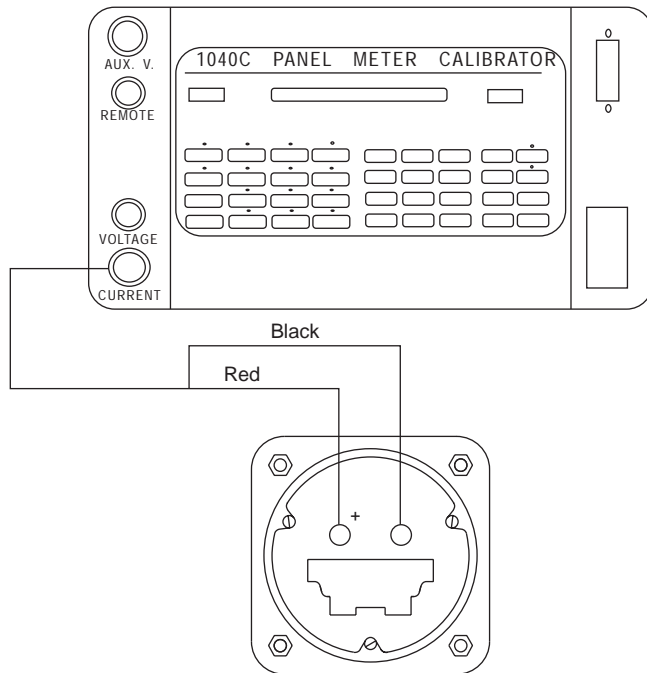

**AC AMMETER
YOKOGAWA 103131**_____

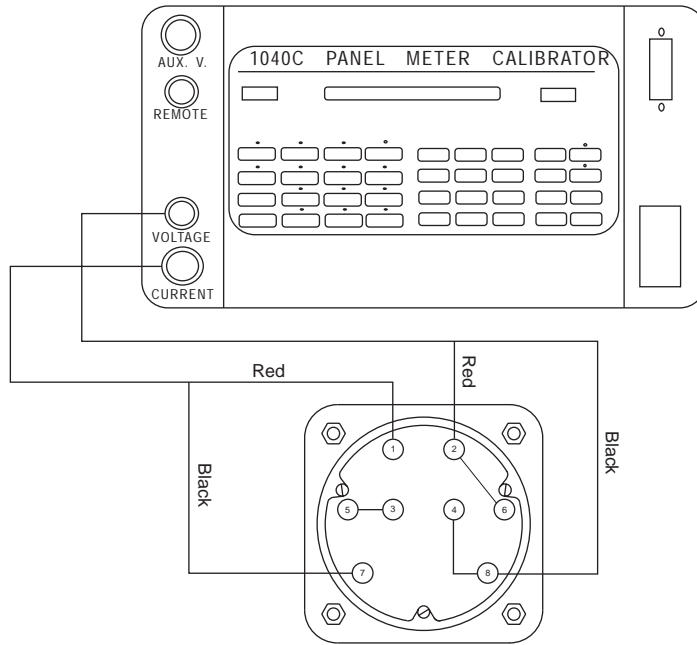

3 WIRE, 3 PHASE WATTMETER
YOKOGAWA 10322 _____
103712 _____

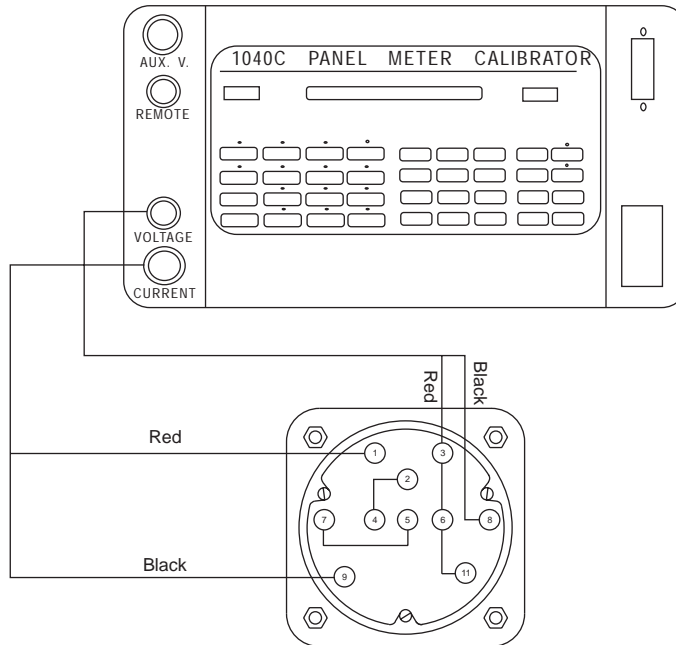

4 WIRE, 3 PHASE WATTMETER
YOKOGAWA 10325 _____
103732 _____

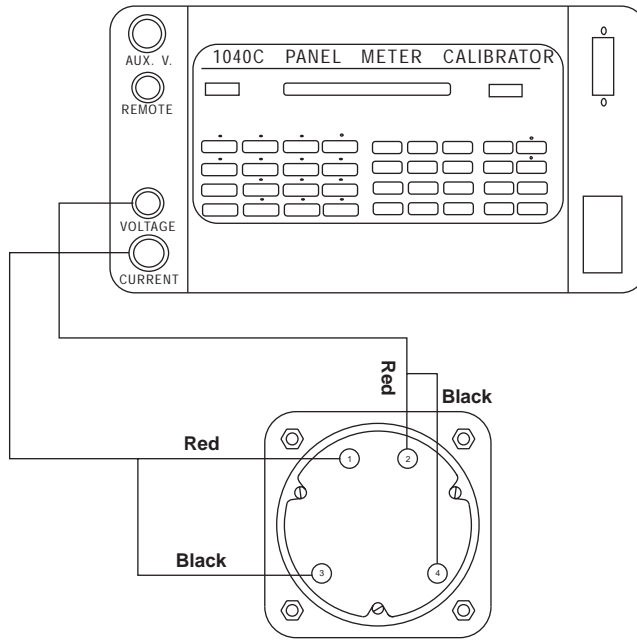

SINGLE PHASE WATTMETER AND VARMETER

- YOKOGAWA** 10321 _____ (WATT)
 103702 _____ (WATT)
 10331 _____ (VAR)
 103762 _____ (VAR)

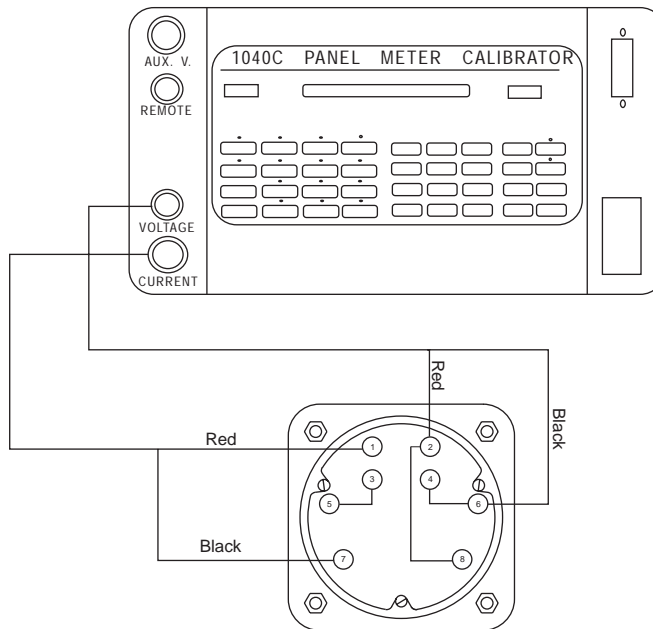

3 WIRE, 3 PHASE VARMETER

- YOKOGAWA** 103812 _____
 10328 _____
 10332 _____
 103772 _____

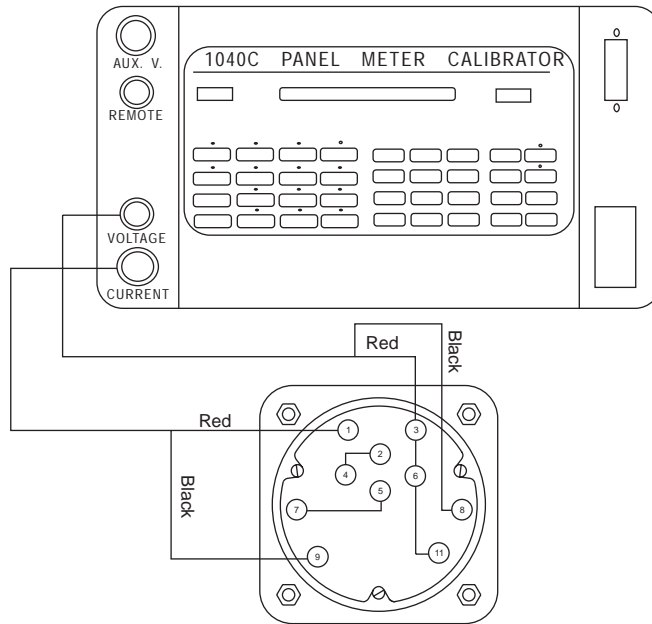

4 WIRE, 3 PHASE, 2 1/2 ELEMENT VAR METER

YOKOGAWA 10329 _____
103742 _____

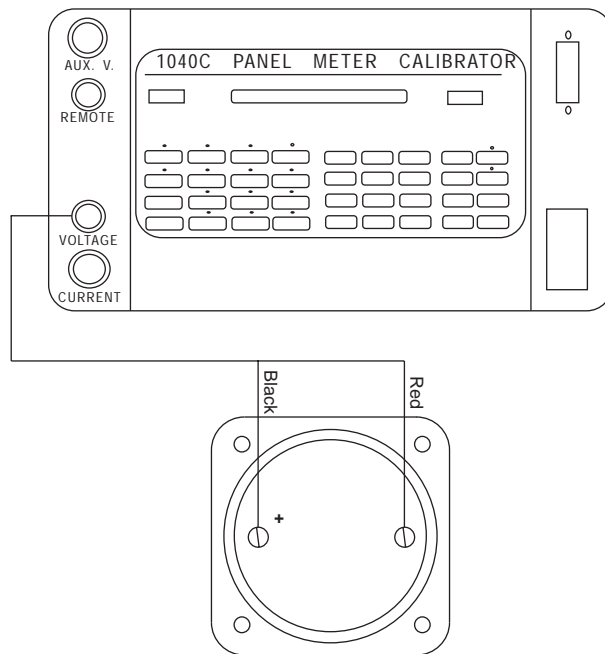

FREQUENCY METER
YOKOGAWA 103372 _____

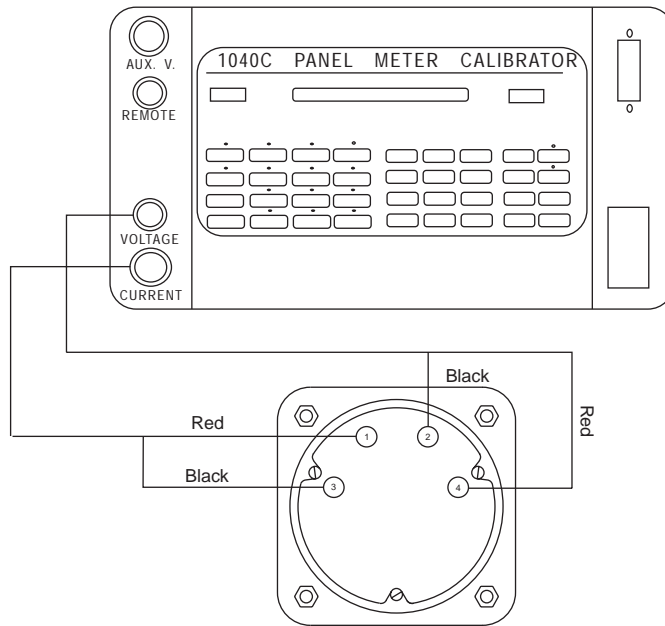

**SINGLE PHASE POWER FACTOR METER
YOKOGAWA 103412 _____**

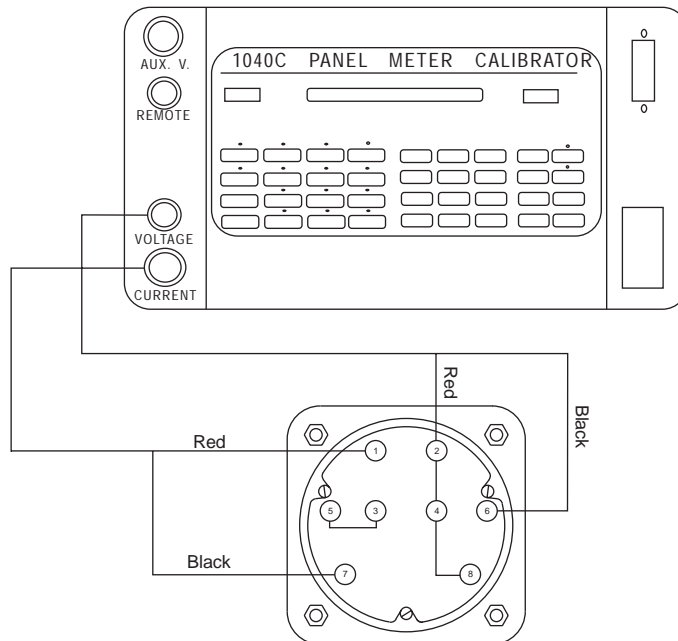

**3 PHASE POWER FACTOR METER
FOR BALANCED SYSTEM
YOKOGAWA 103462 _____**

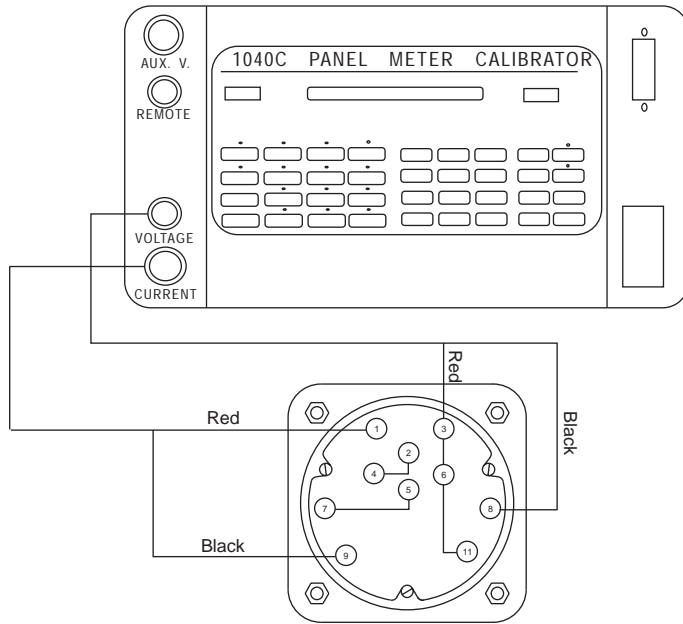

**4 WIRE, 3 PHASE POWER FACTOR METER
YOKOGAWA 103472 _____**